

Table of Contents

CHAPTER 7 BRIDGE LOAD RATING GUIDELINES

7.1	POLICY	7-1
7.1.1	Purpose.....	7-1
7.1.2	Rating Specifications	7-1
7.1.3	Definitions	7-2
7.1.4	Qualifications.....	7-2
7.1.5	Field Verification.....	7-2
7.1.6	Load Rating Software	7-2
7.1.7	Units.....	7-3
7.2	GENERAL LOAD RATING REQUIREMENTS	7-3
7.2.1A	Bridge Projects Designed using LRFD.....	7-3
7.2.1B	Bridge Projects Designed using ASD/LFD	7-3
7.2.2	Elements Requiring Load Rating.....	7-4
7.2.3	Dead Loads	7-5
7.2.4	Live Loads	7-7
7.2.5	Special Instructions for Load Ratings.....	7-14
7.2.6	Special Instructions for Load Ratings of Prestressed Concrete Members including Adjacent Prestressed Concrete Beams.....	7-16
7.2.7	Special Instructions for Load Ratings of Stone Masonry Arches.....	7-17
7.2.8	Special Instructions for Load Rating of Reinforced Concrete Arches.....	7-19
7.2.9	Special Instructions for Load Rating of Corroded Steel Beam Webs.....	7-20
7.2.10	Special Instructions for Load Rating of Deteriorated Prestressed Beams	7-27
7.2.11	Guidelines for Preparing the Evaluation of Rating and Recommendations	7-28
7.3	REPORT SUBMITTAL REQUIREMENTS	7-29
7.3.1	Submittal Requirements.....	7-29
7.3.2	Report Distribution	7-30
7.3.3	Checklist	7-30
7.4	CALCULATIONS AND INPUT FILE FORMAT	7-30
7.4.1	Hand and Electronic Calculations.....	7-30
7.4.2	BrR Input File Submission	7-31
7.4.3	Check of Calculations Submission	7-33
7.5	RATING REPORT.....	7-33
7.5.1	Preparation and Format.....	7-33
7.5.2	Report Organization.....	7-33
7.5.3	Available Plans	7-36

List of Figures

Figure 7.2.7-1:	Stone Masonry Arch Rating Procedure Flow Chart.....	7-19
Figure 7.2.9-1:	Graphic for Corroded Steel Beam Webs	7-20
Figure 7.2.9-2:	Corrosion Patterns for Determining Parameters to be used in Empirical Equation .	7-25
Figure 7.2.10-1:	Example of Spalls and Delamination	7-28
Figure 7.2.10-2:	Deck Beam Cross-Section (see Figure 7.2.10-1).....	7-28
Figure 7.5.2-1:	Report Cover/Title Sheet.....	7-37

Figure 7.5.2-2A: Summary of Bridge Rating (LRFR).....	7-38
Figure 7.5.2-3A(1): Breakdown of Bridge Rating – Steel Beams (LRFR).....	7-39
Figure 7.5.2-3A(2): Breakdown of Bridge Rating – Steel Beams (LRFR).....	7-40
Figure 7.5.2-3A(3): Breakdown of Bridge Rating – Steel Beams (LRFR).....	7-41
Figure 7.5.2-4B: Summary of Bridge Rating (ASR/LFR).....	7-42
Figure 7.5.2-5B(1): Breakdown of Bridge Rating – Steel Beams (ASR/LFR).....	7-43
Figure 7.5.2-5B(2): Breakdown of Bridge Rating – Steel Beams (ASR/LFR).....	7-44
Figure 7.5.2-5B(3): Breakdown of Bridge Rating – Steel Beams (ASR/LFR).....	7-45
Figure 7.5.2-6A: Breakdown of Bridge Rating – Prestressed Beams (LRFR)	7-46
Figure 7.5.2-6B: Breakdown of Bridge Rating – Prestressed Beams (LFR)	7-47
Figure 7.5.2-7: Breakdown of Bridge Rating – Alternative Rating Using Actual Lane Location....	7-48
Figure 7.5.2-8: Description of Bridge.....	7-49
Figure 7.5.2-9: Comparison of Ratings.....	7-50
Figure 7.5.2-10A: Vehicle Diagrams (LRFR)	7-51
Figure 7.5.2-10B: Vehicle Diagrams (ASR/LFR)	7-52
Figure 7.5.2-11: Vehicle Diagrams – Specialized Hauling Vehicles.....	7-53
Figure 7.5.2-12: Vehicle Diagrams – Emergency Vehicles.....	7-54
Figure 7.5.2-13A: Vehicle Diagrams – HL-93	7-55

List of Tables

Table 7.2.4-1: Live Load Distribution Constant for Prestressed Adjacent Beams	7-10
Table 7.2.5-1: Concrete Strengths by Mix Design.....	7-15
Table 7.2.5-2: Prestressed Concrete Strength by Date of Production.....	7-16
Table 7.2.5-3: Prestressed Strand Strength by Date of Production.....	7-16
Table 7.2.9-1: Values of Factor (m) - for Average Web Thickness Calculation	7-22
Table 7.2.9-2: Factors for Calculating $R_{n(2)}$ when $N/d > 0.2$	7-23
Table 7.2.9-3: Factors for Calculating $R_{n(2)}$ when $N/d \leq 0.2$	7-23
Table 7.2.9-4: Parameters Based on Corrosion Pattern for $R_{n(3)}$ Equation	7-26

Bridge Load Rating Report Checklist

CHAPTER 7

BRIDGE LOAD RATING GUIDELINES

7.1 POLICY

7.1.1 Purpose

This chapter establishes policy to be used by MassDOT and Consultant Rating Engineers in determining the safe load carrying capacity of newly built and existing bridges. The development of a bridge load rating requires engineering judgment and the implementation of sound engineering principles that are commonly accepted in the field of bridge engineering.

Load rating for a bridge shall be performed using the same methodology that was used for its design. The majority of existing bridges in the Commonwealth of Massachusetts were designed using the Allowable Stress Design (ASD) method. In general, the Central Artery bridges were designed using the Load Factor Design (LFD) method and more recently all bridges have been designed using the Load and Resistance Factor Design (LRFD) method. It is the responsibility of the Rating Engineer to determine the method that will be used for development of the load rating.

The initial load rating, typically submitted by the Design Engineer as the Rating Engineer, shall be submitted in accordance with the MassDOT Bridge Manual that was in effect at the time of the completion of design. The Rating Engineer shall clearly identify which version of the Bridge Manual was used for reference in the Available Plans, Inspection Reports, and References section of the Load Rating Report. Any unique assumptions that were used during the design process shall be identified by the Rating Engineer so that future load ratings can include these assumptions, if MassDOT and the Rating Engineer agree that they are still valid.

Load ratings are performed to evaluate and identify substandard bridges requiring posting, and to assist in determining the bridges requiring rehabilitation or replacement. Load ratings shall not be used as the sole basis for project scopes, but shall be used in combination with the available inspection information, field verification, and engineering judgement. Additionally, FHWA requires reporting of bridge load ratings on an annual basis.

Massachusetts General Laws require the determination of the maximum weight of vehicle with load which a bridge will safely carry for the Rating Vehicles as defined in the sections that follow.

FHWA memoranda, specifically Load Rating of Specialized Hauling Vehicles, dated November 15, 2013, and Load Rating for the FAST Act's Emergency Vehicles, dated November 3, 2016 identify additional Rating Vehicles to be load rated. FHWA has information regarding the load rating of these vehicles on the Bridges and Structures page of their Program Policy & Guidance Center website. <https://www.fhwa.dot.gov/bridge/loadrating/>

7.1.2 Rating Specifications

All bridges shall be rated in accordance with the provisions of the current *AASHTO Manual for Bridge Evaluation*, including all Interims except where modified by this Bridge Manual.

Section 6 of the *AASHTO Manual for Bridge Evaluation* is divided into two parts. Part A of the *AASHTO Manual for Bridge Evaluation* incorporates provisions specific to the Load and Resistance Factor Rating (LRFR) methodology, whereas Part B provides rating criteria and procedures for the Allowable Stress Rating (ASR) and Load Factor Rating (LFR) methods of evaluation.

In the articles that follow a designation of “A” or “B” is used to differentiate between the LRFR methodology and the Allowable Stress/Load Factor methodology, respectively.

7.1.3 Definitions

For the purpose of these guidelines, the following definitions shall be used:

BrR – AASHTOWare™ Bridge Rating, version currently in use by MassDOT at the time a load rating is performed

MS18 – metric equivalent of the HS20

Statutory – the total weight specified for a given Rating Vehicle or notional load

7.1.4 Qualifications

All bridge ratings shall be prepared under the direction of a Rating Engineer who shall be a Professional Engineer registered in the Commonwealth of Massachusetts in Responsible Charge of the work, or by a MassDOT Engineer under the direction of the State Bridge Engineer. Engineers performing the analysis shall be knowledgeable in bridge design and familiar with the relevant AASHTO specifications.

All bridge ratings shall also be reviewed by an Independent Reviewer who is a Professional Engineer registered in the Commonwealth of Massachusetts and who will sign the Statement of Concurrence as required in Subsection 7.4.3.

7.1.5 Field Verification

The Rating Engineer shall field verify what is contained on the latest plans, latest inspection reports, and prior bridge rating reports. If during the verification, the Rating Engineer finds a changed condition that is not noted or documented sufficiently on the latest inspection report, the Rating Engineer shall notify the State Bridge Engineer, and shall obtain documented measurements of the changed condition prior to incorporating the findings and the documented measurements into the Rating Report. Section losses used to calculate load ratings shall not be based on assumed conditions.

If during the field verification, a condition that meets the definition of a Critical-Structural or Critical-Hazard Deficiency is identified, the Rating Engineer shall follow the requirements of Section 4.7, CS/I & CH/I Procedure and Documentation, of the MassDOT Bridge Inspection Handbook for guidance on action that shall be taken.

7.1.6 Load Rating Software

7.1.6.1 MassDOT currently utilizes AASHTOWare™ Bridge Rating (BrR) software (formerly known as Virtis) as the standard software for load rating purposes. The assignment letter will provide the Rating Engineer with the required version of BrR, which is presently used by the Bridge Section. It is the Rating Engineer’s responsibility to ensure that ratings are being performed with the correct release. The Rating Engineer is also responsible for checking with the BrR Support Center for any known software issues that could affect the rating results. If issues found with BrR in the process of rating a structure cannot be resolved prior to submitting the report, then they shall be addressed through alternative calculations and documented in the Rating Analysis Assumptions and Criteria section of the Rating Report. When using BrR to perform the load rating, unique requirements to run the analysis file

shall be noted in the Analysis Assumptions and Criteria. For example, analyses requiring the file to be run using BrR's 3D FEM option shall be explicitly identified.

7.6.1.2 Where the Rating Engineer determines, and the State Bridge Engineer concurs, that a structure cannot be properly analyzed using the BrR load rating software, the Rating Engineer shall discuss the software proposed with the State Bridge Engineer prior to developing a scope and fee for the rating.

7.6.1.3 Depending on the complexity of the rating, it may be necessary to develop a simplified method for reviewing the structure to allow for the analysis of permit loads and other future loads. This requirement shall be discussed with the State Bridge Engineer for all bridges that cannot be run solely using BrR.

7.1.7 Units

7.1.7.1 All bridge ratings shall be performed using U.S. Customary units. If the bridge was designed and detailed using metric units, the bridge geometry and section properties shall be converted using exact conversion factors and the rating calculations shall be prepared using U.S. Customary units.

7.1.7.2B In accordance with requirements of the December 1995 FHWA NBIS Coding Guide an Inventory and Operating Rating shall be obtained for the HS20 vehicle using the Load Factor Method. Timber and stone masonry structures are exempt from this requirement and shall be reported based upon the Allowable Stress Method. The gross tonnage is reported on the Summary of Bridge Rating of the rating report for Item 64 and Item 66. Since MassDOT reports these Items in metric units, the gross tonnage results from the rating calculations performed in U.S. Customary units shall be converted to metric units. The HS20 truck gross tonnage shall be converted to an MS18 gross tonnage using a conversion factor of 0.9, instead of the exact conversion of 0.907185 metric tons per U.S. short ton. An MS Equivalent to Items 64 and 66 shall be calculated by dividing the MS18 gross tonnage by 1.8. The resulting MS18 metric ton ratings and MS Equivalent shall be specified on the Summary of Bridge Rating in the spaces provided for Item 64 and Item 66. The header in the MS18 FHWA NBIS CODING GUIDE table in the Summary of Bridge Rating shall be revised to note Allowable Stress Rating rather than Load Factor Rating for timber and stone masonry structures.

7.2 GENERAL LOAD RATING REQUIREMENTS

7.2.1A Bridge Projects Designed using LRFD

Ratings for bridges designed using LRFD shall be based on the plans, as-built conditions and the latest bridge inspection reports. The ratings shall be performed using the LRFR methodology in accordance with Part A of the *AASHTO Manual for Bridge Evaluation*. For bridges that have not been rated previously, ratings shall be provided using as-built member properties and the reported and field verified section losses.

7.2.1B Bridge Projects Designed using ASD/LFD

Ratings for bridges designed using ASD or LFD shall be based on the plans, as-built conditions and the latest bridge inspection reports. The ratings shall be performed using the appropriate rating methodology, i.e. ASR for ASD designed bridges and LFR for LFD designed bridges, in accordance with Part B of the *AASHTO Manual for Bridge Evaluation*. For bridges that have not been rated previously, ratings shall be provided using as-built member properties and the reported and field verified section losses.

7.2.2 Elements Requiring Load Rating

7.2.2.1 Stringer/girder bridges will require ratings for the primary elements using a Girder System in BrR, whenever possible. The Rating Engineer shall rate the following “points of interest” along the girder length:

- 0.5L for simple span bridges
- Maximum positive dead load moment location in each span of continuous bridges
- Points of support, except as noted below for concrete beams
- Location of change(s) in the girder cross section
- Theoretical (not actual) cover plate cut-off locations
- Locations of measurable section loss
- Repair locations
- Locations where there are reinforcement discontinuities in concrete members
- The critical shear location, as defined by AASHTO, of the prestressed or reinforced concrete beams, in lieu of the points of support.
- Hold down points for draped strands in prestressed concrete beams
- Theoretical development location of debonded stands in prestressed concrete beams
- Any other location that controls.

7.2.2.2 For girder/floorbeam/stringer bridges and girder/floorbeam bridges using a Floor System in BrR, whenever possible. All elements shall be rated at locations similar to those outlined in Paragraph 7.2.2.1 above.

7.2.2.3A For truss bridges all chords, diagonals, floorbeams, stringers, bracing, and gusset plates require load ratings using a Truss System in BrR, whenever possible. Floorbeams and stringers shall be rated for flexure and shear, and any loss of section shall be accounted for. All main member gusset plates shall be rated in accordance with the *AASHTO Manual for Bridge Evaluation* and accounting for any loss of section.

7.2.2.3B For truss bridges all chords, diagonals, floorbeams, stringers, bracing, and gusset plates require load ratings. Floorbeams and stringers shall be rated for flexure and shear, and any loss of section shall be accounted for. Due to the inability of BrR to perform complete ASD load ratings for truss members, these ratings shall be performed by using BrR to develop member forces, but all capacity and rating factor calculations shall be performed outside of BrR. Other MassDOT approved software may be used in the same manner, however an explanation regarding how to export results from the analysis and import them into the calculations shall be provided.

All main member gusset plates shall be rated using LFR for both ASD and LFD designed trusses in accordance with the *AASHTO Manual for Bridge Evaluation* and accounting for any loss of section.

7.2.2.4 For straight stringer bridges a more refined analysis (2D or 3D) shall not be used unless the original design was based upon it, and it is approved by the State Bridge Engineer. The request to use a more refined method of analysis to rate the structure needs to include justification as to why a 1D

analysis is insufficient. Note, that if the Rating Engineer includes diaphragms or cross frames in their more refined method of analysis model, they are to be considered primary members and shall be rated.

7.2.2.5 For curved girder bridges, a more refined analysis is required, such as 2D or 3D. This analysis shall include the diaphragms or cross frames, and these elements shall also be rated.

7.2.2.6 For concrete, stone, and masonry arches, at a minimum, the crown, springlines and quarter points shall be rated.

7.2.2.7 Bridge Decks. Reinforced concrete decks and exodermic bridge decks supported by girders or floorbeams do not require load ratings unless their condition warrants investigation. If the Rating Engineer considers that the deck should be rated based upon condition or other concerns, he/she shall consult with the Bridge Section regarding the potential inclusion of the deck rating in their proposal.

In the event that the reinforced concrete deck needs to be rated, the Rating Engineer shall check punching shear under wheel loads and not check flexure, as discussed in *AASHTO Manual for Bridge Evaluation*, Article C6.1.5.1.

- Timber decks require a load rating.
- Vaulted sidewalks that have thin (less than 5½”) deck slabs shall require a punching shear check.
- Metal grid decks do not require a load rating, but purlins supporting the metal grid decking shall be rated.

Rating alternative deck types (i.e. orthotropic, sandwich-plate, FRP, etc.) will be considered on a case-by-case basis and shall be discussed with the Bridge Section prior to developing a scope and fee for the rating.

7.2.2.8 Bolted or field welded splices for steel rolled shapes, built up members, or welded plate girders shall not be rated unless their condition warrants investigation. If the Rating Engineer considers that the splices should be rated based upon condition, he/she shall consult with the Bridge Section regarding the potential inclusion or addition of the splice ratings in the scope.

7.2.2.9 Alternate Load Path. An Alternate Load Path is the path that an applied load can take through other structural members to bypass a primary member that has little or no load carrying capacity. An Alternate Load Path allows a structure to continue to function without a failure, albeit perhaps in a reduced capacity. An example would be a deck that spans over a primary load path beam with a zero-ton rating, thereby transferring the wheel load to the adjacent, sound beams. For bridges which may require posting, the Rating Engineer shall consider and define all structurally feasible alternate load paths and rate the members that make up these alternate load paths to determine if they produce a higher overall bridge rating than the one based on the rating of the primary load carrying member(s). Prior to undertaking the rating of alternate load path members, the Rating Engineer shall consult with the Bridge Section and obtain concurrence that these load paths are viable.

7.2.3 Dead Loads

7.2.3.1 If a material unit weight is not known, Table 3.5.1-1 of the *AASHTO LRFD Bridge Design Specifications* shall be used for guidance.

7.2.3.2 For stringer bridges, dead loads and superimposed dead loads shall be distributed based on provisions of Subsection 3.5.3 of this Bridge Manual. The wearing surface shall be distributed equally

to all beams in the cross section. For simplicity, and in order to keep the dead load moment diagram symmetrical, interior diaphragms shall be distributed as an equivalent uniform load over the length of the stringer. Fully and partially encased concrete end diaphragms shall be applied as point loads if, in the opinion of the Rating Engineer, this will affect the controlling rating.

7.2.3.3 For NEXT F and D Beams, dead loads and superimposed dead loads shall be distributed based on the provisions of Subsection 3.5.4 of this Bridge Manual.

7.2.3.4 For adjacent beam prestressed deck and box beam systems with a composite concrete slab, dead loads and superimposed dead loads shall be distributed based on the provisions of Subsection 3.8.2 of this Bridge Manual.

7.2.3.5 When analyzing adjacent prestressed deck and box beam systems without a composite concrete slab whose shear keys are intact and functioning, all superimposed dead loads shall be distributed as outlined in Subsection 3.8.2 of this Bridge Manual.

When the shear keys have failed, and there is no composite feature, such as a sidewalk or median, the Rating Engineer shall distribute the dead loads consistent with the way the bridge is performing, assuming no transfer of load across the failed keys. The beams shall be assumed to carry the loads applied directly to them, using tributary widths to determine the load carried by each beam.

When the shear keys have failed, but beams are tied to each other with composite features, such as a sidewalk or median, all superimposed dead loads shall be distributed to the tied beams as outlined in Subsection 3.8.2 of this Bridge Manual assuming the composite feature acts as a deck. The centerline of the de facto deck shall be used as the centerline about which to consider the eccentricities for the pile cap analogy.

7.2.3.6B For concrete slab bridges, the distribution of superimposed dead loads shall be determined after careful review of the plans.

If the slab has consistent reinforcing throughout the cross section, the superimposed dead loads (safety curb, sidewalk, and bridge barrier) shall be distributed equally across the entire bridge cross section. If a portion of the slab supporting the sidewalk/bridge barrier or safety curb has an increased section or increased reinforcing, 60% of the superimposed sidewalk/bridge barrier or safety curb dead loads shall be carried by this portion of the slab and the remaining 40% of these superimposed dead loads shall be carried by the remainder of the slab.

For concrete slab bridges the wearing surface shall be distributed to the entire bridge cross section.

7.2.3.7 For truss-floorbeam-stringer or girder-floorbeam-stringer system bridges all dead loads shall be distributed to floorbeams and trusses (or girders) as end reactions of the stringer or floorbeams using statics. The dead load distribution methods used for longitudinal multi-stringer bridges do not apply to these systems.

7.2.4 Live Loads

7.2.4.1A HL-93 Design Load is the LRFD Design Live Load as per Appendix C6A of the *AASHTO Manual for Bridge Evaluation* and shall be analyzed to determine a rating factor.

Rating Vehicles shall be as follows:

H20 truck	Two Axle	20 Tons
Type 3 truck	Three Axle	25 Tons
Type 3S2 truck	Five Axle	36 Tons
SU4 ¹	Four Axle	27 Tons
SU5 ¹	Five Axle	31 Tons
SU6 ¹	Six Axle	34.75 Tons
SU7 ¹	Seven Axle	38.75 Tons
Type EV2 ²	Two Axle	28.75 Tons
Type EV3 ²	Three Axle	43 Tons

Please note that MassDOT defines **Posting Vehicles** as trucks whose load ratings are used when a bridge is posted. MassDOT currently uses the following posting trucks for posting purposes at Inventory Level:

H20 truck	Two Axle	20 Tons
Type 3 truck	Three Axle	25 Tons
Type 3S2 truck	Five Axle	36 Tons

Note 1: NCHRP Report 575 investigated the current truck configurations operating nationwide and determined that the AASHTO Legal Loads underestimate the load effects of the actual Specialized Hauling Vehicles (SHVs) currently operating in most states. In 2005, AASHTO adopted the SU4, SU5, SU6, and SU7 truck models which are intended to capture the effects of these SHVs.

Note 2: Type EV2 and Type EV3 have been added to the Rating Vehicles as a result of the implementation of Fixing America's Surface Transportation Act (FAST Act) signed into law by the President on December 4, 2015. This act provided an exemption for emergency vehicles from the nationwide Interstate truck weight limits set forth in 23 U.S.C. 127(a). This requirement applies to all bridges within reasonable access to the Interstate System.

MassDOT has chosen to rate the interior beams of all bridges for the effects of Fast Act Emergency Vehicle loadings. The Rating Engineer may need to consider the first interior roadway beam and exterior safety curb beams depending upon the actual roadway lane striping. It shall be noted that first interior beams are always associated with the presence of a sidewalk, and not a safety curb. Additionally, superstructure members supporting these beams (e.g. floorbeams, trusses, etc.) will need to be rated for these vehicles.

7.2.4.1B **Rating Vehicles** shall be as follows:

H20 truck	Two Axle	20 Tons
Type 3 truck	Three Axle	25 Tons
Type 3S2 truck	Five Axle	36 Tons
HS20 truck	Three Axle	36 Tons
SU4 ¹	Four Axle	27 Tons
SU5 ¹	Five Axle	31 Tons
SU6 ¹	Six Axle	34.75 Tons
SU7 ¹	Seven Axle	38.75 Tons
Type EV2 ²	Two Axle	28.75 Tons
Type EV3 ²	Three Axle	43 Tons

Please note that MassDOT defines **Posting Vehicles** as trucks whose load ratings are used when a bridge is posted. MassDOT currently uses the following posting trucks for posting purposes at Inventory Level:

H20 truck	Two Axle	20 Tons
Type 3 truck	Three Axle	25 Tons
Type 3S2 truck	Five Axle	36 Tons

Note 1: NCHRP Report 575 investigated the current truck configurations operating nationwide and determined that the AASHTO Legal Loads underestimate the load effects of the actual Specialized Hauling Vehicles (SHVs) currently operating in most states. In 2005, AASHTO adopted the SU4, SU5, SU6, and SU7 truck models which are intended to capture the effects of these SHVs.

Note 2: Type EV2 and Type EV3 have been added to the Rating Vehicles as a result of the implementation of Fixing America's Surface Transportation Act (FAST Act) signed into law by the President on December 4, 2015. This act provided an exemption for emergency vehicles from the nationwide Interstate truck weight limits set forth in 23 U.S.C. 127(a). This requirement applies to all bridges within reasonable access to the Interstate System.

MassDOT has chosen to rate the interior beams of all bridges for the effects of Fast Act Emergency Vehicle loadings. The Rating Engineer may need to consider the first interior roadway beam and exterior safety curb beams depending upon the actual roadway lane striping. It shall be noted that first interior beams are always associated with the presence of a sidewalk, and not a safety curb. Additionally, superstructure members supporting these beams (e.g. floorbeams, trusses, etc.) will need to be rated for these vehicles.

7.2.4.2A Bridges shall be rated for Inventory and Operating Level with the HL-93 design live load, as defined by Part A of the *AASHTO Manual for Bridge Evaluation*. The resulting rating factors for roadway beams shall be specified on the Summary of Bridge Rating in the spaces provided for Item 64 and Item 66. Sidewalk beam rating factors shall not be reported in the Summary. Due to limitations in NBIS coding, the rating factors shall not be reported at a value greater than 3.0. If the calculated rating factors shown in the Breakdown of Bridge Rating exceed 3.0, report 3.0 in the Summary of Bridge Rating.

These bridges shall be rated for the H20, Type 3, Type 3S2, SU4, SU5, SU6, and SU7 vehicles outlined above. The ratings and the corresponding gross tonnage for each of these vehicles shall be reported at both the Inventory and Operating Level for the Limit States contained in Table B6A-1 of

the *AASHTO Manual for Bridge Evaluation*, except that the Fatigue Load limit state shall not be evaluated. The Load Factors, both dead and live load, for all vehicles shall be the Inventory and Operating factors listed for the Design Load. However, for limit states other than Strength I only report values if the rating factor is less than 1.0.

7.2.4.2B Bridges shall be rated based on the method used for design. For most bridges the ratings will be performed using Allowable Stress Methods. There are existing bridges designed and constructed during the Central Artery timeframe that were designed using Load Factor Method. These bridges shall be rated using the Load Factor Method.

These bridges shall be rated for the H20, Type 3, Type 3S2, HS20, SU4, SU5, SU6, and SU7 vehicles outlined above. The ratings and the corresponding gross tonnage for each of these vehicles shall be reported at both the Inventory and Operating Level.

The MS18 gross tonnage for roadway beams, as specified in Paragraph 7.1.7.2B shall be specified on the Summary of Bridge Rating in the spaces provided for Item 64 and Item 66. Sidewalk beam gross tonnage shall not be reported in the Summary.

Both Inventory and Operating Ratings shall be calculated for the Rating Vehicles outlined above. In general, lane loadings shall not be used for the H20 and HS20 vehicles when the span length is less than 200 feet. However, if a component of a structure is rated for the H vehicle, and the rating is determined to be 12 tons or less, this component must also be rated using the lane loading.

The above 12-ton limitation is based upon the 1978 *AASHTO Manual for Maintenance Inspection of Bridges*, which states in 5.2.2 “*The probability of having a series of closely spaced vehicles of the maximum allowed weight becomes greater as the maximum allowed weight for each unit becomes less. That is, it is more likely to have a train of light-weight vehicles than it is to have a train of heavy-weight vehicles.*”

For spans greater than 200 feet in length, the load effect of the Type 3 and Type 3S2 vehicles shall be modeled as a lane-type loading, similar to that shown in the *AASHTO Manual for Bridge Evaluation*, Figure D6A-4. Each lane-type loading shall consist of a legal lane weight of 0.20 klf concurrent with a vehicle that is 75% of the weight of the applicable vehicle as shown in Figure 7.10B. A single vehicle load of the same type shall be placed in the adjacent lane(s). For continuous span bridges, where at least one span is greater than 200 feet in length, an additional model for negative moment and interior reactions shall apply. The model for continuous span negative moment and interior reaction shall be a lane-type loading, similar to that shown in the *AASHTO Manual for Bridge Evaluation*, Figure D6A-5. Each continuous span lane-type loading shall consist of a legal lane weight of 0.20 klf concurrent with two vehicles that are 75% of the weight of the applicable vehicle as shown in Figure 7.10B, with the two vehicles spaced with 30 feet clear distance between vehicles. A single vehicle load of the same type shall be placed in the adjacent lane(s). For the H20 and HS20 vehicles, the standard lane loading with concentrated load(s), including the provisions for lane loads on continuous spans, as defined by the *AASHTO Standard Specifications*, shall be used. Lane-type loadings are not required to be considered for the SU or EV vehicles.

.For bridges composed of adjacent precast beams, including prestressed deck slabs and box beams, with functioning shear keys, with or without a composite concrete slab, the equations from Article 3.23.4 of the *AASHTO Standard Specifications for Highway Bridges* shall be superseded by the following equations for live load bending moment distribution from the 13th Edition of the *AASHTO Standard Specifications for Highway Bridges*. In calculating the bending moments no longitudinal distribution of wheel load shall be assumed.

Load Fraction = S/D

Where: $S = \frac{12N_l + 9}{N_g}$

For $C \leq 3$ $D = 5 + \frac{N_l}{10} + \left(3 - \frac{2N_l}{7}\right) \left(1 - \frac{C}{3}\right)^2$

For $C > 3$ $D = 5 + \frac{N_l}{10}$

Where:

- N_l = Number of traffic lanes. Note that this number may vary from 1 to the total number of lanes to allow for calculation of the Force Effect due to Adjacent Vehicle
- N_g = Total number of longitudinal beams
- C = $K(W/L)$, a stiffness parameter
- W = Overall width of the bridge (ft)
- L = Span length (ft)

Values of K to be used in $C = K(W/L)$:

Table 7.2.4-1: Live Load Distribution Constant for Prestressed Adjacent Beams

Bridge Type	Beam Type and Deck Material	K
Multi-Beam	Nonvoided rectangular beams	0.7
	Rectangular beams with circular voids	0.8
	Box section beams	1.0
	Channel Beams	2.2

7.2.4.3A The Type EV2 and Type EV3 shall be rated and the corresponding gross tonnage for each of these vehicles shall be reported at the Strength I Limit State for Operating Level only, using the load factors for dead loads contained in Table B6A-1 of the *AASHTO Manual for Bridge Evaluation* and a load factor of 1.3 for live load as advised by FHWA. The live load distribution factor should be the One Design Lane Loaded factor from the *AASHTO LRFD Bridge Design Specifications* with the built-in multiple presence factor of 1.2 divided out. Using BrR this would require an additional model to run the EV vehicles, which is not required.

Interior beams shall be rated with the Type EV2 or Type EV3 in one lane, and a Type 3S2 vehicle in an adjacent lane(s). The Type 3S2 vehicle is the only adjacent Rating Vehicle that needs to be considered.

When using BrR to determine the rating for the Type EV2 and Type EV3 vehicles, the rating vehicle shall be defined as a Permit Load Rating and the Type 3S2 shall be defined as the Adjacent Vehicle. Under the Advanced Vehicle Properties, check “override” and input 1.3 for the Permit Live Load Factor. Additionally, the Adjacent Vehicle Live Load Factor shall be set as 1.3.

When not using BrR, use the modified *AASHTO LRFD Bridge Design Specifications* Article 4.6.2.2.5 equations below to determine the force effect on the structural member being rated for the Type EV2 or EV3 and Type 3S2 adjacent vehicle.

$$LL = G_{EV} * \frac{g_1}{Z}$$

$$AdjLL = G_{ADJ} * \left(g_m - \frac{g_1}{Z} \right)$$

Where:

LL	=	Final Force Effect due to Rating Vehicle Live Load (EV2 or EV3) to be applied in rating equation
G_{EV}	=	Force Effect due to Emergency Vehicle
g_1	=	Single lane live load distribution factor
Z	=	A factor taken as 1.20 where the lever rule was not utilized, and 1.0 where the lever rule was used for a single lane live load distribution factor
AdjLL	=	Force Effect due to Adjacent Vehicle (Type 3S2) to be applied in rating equation
G_{ADJ}	=	Force Effect due to Adjacent Vehicle (Type 3S2)
g_m	=	Multiple lane live load distribution factor

In all cases the Rating Factor for the Type EV2 and EV3 vehicles shall be determined using the following formula:

$$RF = \frac{(C - \gamma_{DC} * DL - \gamma_D * DW - \gamma_{ADJ} * AdjLL)}{\gamma_{LL} * LL}$$

Where:

RF	=	Rating Factor
C	=	Capacity
γ_{DC}	=	Load Factor for components and attachments
DL	=	Force Effect due to components and attachments
γ_{DW}	=	Load Factor for wearing surfaces and utilities
DW	=	Force Effect due to wearing surfaces and utilities
γ_{ADJ}	=	Load Factor for Adjacent Vehicle = 1.3
AdjLL	=	Force Effect due to Adjacent Vehicle
γ_{LL}	=	Load Factor for Rating Vehicle = 1.3
LL	=	Force Effect due to Rating Vehicle Live Load

7.2.4.3B The Type EV2 and Type EV3 shall be rated and the corresponding gross tonnage for each of these vehicles shall be reported at the Operating Level only. If the Load Factor Method is required, the Operating Level shall be obtained by using the load factor for live load (β_L or A2) equal to 1.30. The live load distribution factor shall be the “Bridge Designed for One Traffic Lane” taken from the *AASHTO Standard Specifications for Highway Bridges*.

Interior beams shall be rated with the Type EV2 or Type EV3 in one lane, and a Type 3S2 vehicle in an adjacent lane(s). The Type 3S2 vehicle is the only adjacent Rating Vehicle that needs to be considered.

When using BrR to determine the rating for the Type EV2 and EV3 vehicles, the rating vehicle shall be defined as Permit Operating and the Type 3S2 shall be defined as the Adjacent Vehicle. Under the Advanced Vehicle Properties, the Adjacent vehicle live load factor shall be set as 1.0 for an Allowable Stress Rating and 1.3 for a Load Factor Rating. Under the Live Load Distribution tab for each Member

Alternative check the box for “Allow Distribution factors to be used to compute effects of permit loads with routine traffic”.

When not using BrR, use *AASHTO Standard Specifications for Highway Bridges* Table 3.23.1 to calculate the live load distribution factors for a Bridge Designed for One Traffic Lane and Bridge Designed for Two or more Traffic Lanes. The Live Load Distribution Factor for the adjacent vehicle shall be the difference between these two live load distribution factors. The live load distribution factor for the Type EV2 and EV3 vehicles shall be that for a Bridge Designed for One Traffic Lane.

$$LL = G_{EV} * g_1$$

$$AdjLL = G_{ADJ} * (g_m - g_1)$$

Where:

LL	=	Final Force Effect due to Rating Vehicle Live Load (EV2 or EV3) to be applied in rating equation
G_{EV}	=	Force Effect due to Emergency Vehicle
g_1	=	Live load distribution factor for Bridge Designed for One Traffic Lane
AdjLL	=	Force Effect due to Adjacent Vehicle (Type 3S2) to be applied in rating equation
G_{ADJ}	=	Force Effect due to Adjacent Vehicle (Type 3S2)
g_m	=	Live load distribution factor for Bridge Designed for Two or more Traffic Lanes

In all cases the Rating Factor for the Type EV2 and EV3 vehicles shall be determined using the following formula:

$$RF = \frac{(C - A1 * (DC + DW) - A3 * AdjLL)}{A2 * LL}$$

Where:

RF	=	Rating Factor
C	=	Capacity
A1	=	Dead Load Factor
DC	=	Force Effect due to Stage 1 Dead Load
DW	=	Force Effect due to Stage 2 Dead Load
A3	=	Adjacent Vehicle Live Load Factor
	=	1.0 for Allowable Stress Rating
	=	1.3 for Load Factor Rating
AdjLL	=	Force Effect due to Adjacent Vehicle
A2	=	Live Load Factor
	=	1.0 for Allowable Stress Rating
	=	1.3 for Load Factor Rating
LL	=	Force Effect due to Rating Vehicle Live Load

7.2.4.4A Live load distribution factors for interior and exterior beams shall be calculated in accordance with Chapter 3 of this Bridge Manual and Section 4 of the latest edition of the *AASHTO LRFD Bridge Design Specifications* including all Interims. Skew correction factors shall be included. The provisions of Paragraph 7.2.4.5 below shall apply if need be. The Rating Engineer shall provide calculations for Live Load Distribution Factors which shall be summarized in a table in Appendix C. BrR alone shall

not be used to calculate distribution factors unless the values calculated by BrR match those independently calculated by the Rating Engineer.

7.2.4.4B Live load distribution factors for interior beams shall be calculated in accordance with Section 3 of the *AASHTO Standard Specifications for Highway Bridges*. For exterior beams, use lever rule with the wheel line located 2 feet from the face of the curb and ignore the provisions of Article 3.23.2.3.1.5. However, the provisions of Paragraph 7.2.4.5 below shall apply if need be. The Rating Engineer shall provide calculations for Live Load Distribution Factors which shall be summarized in a table in Appendix C. BrR alone shall not be used to calculate distribution factors unless the values calculated by BrR match those independently calculated by the Rating Engineer.

7.2.4.5 In the event that the exterior or first interior beam rates below statutory, the Rating Engineer shall use an alternative method of distributing the truck load by using the actual travel lanes on the bridge for the placement of the truck, as specified in Articles 6A.2.3.2 and 6B.6.2.2 of the latest edition of the *AASHTO Manual for Bridge Evaluation*. A wheel line of the truck may be placed directly on the outside stripe of the actual travel lane (which shall be field-verified by the Rating Engineer), but no closer than 2 feet to the face of the curb. The live load distribution factor shall be calculated using lever rule with Multiple Presence Factor applied.

The rating value for the exterior beam or first interior obtained by using this alternate method of live load distribution and identified as “Alternative Load Rating using Actual Lane location”, shall be reported in the Breakdown of Bridge Rating of the Bridge Rating report alongside the value obtained by using procedures of Paragraphs 7.2.4.4A and 7.2.4.4B above. However, the higher value shall be reported as the controlling ratings and provided in the Summary of Bridge Rating.

7.2.4.6A Dynamic Load Allowance shall apply to all trucks used in the development of the load rating. Reductions of the Dynamic Load Allowance shall not be permitted, except as follows.

The Dynamic Load Allowance for concrete arches, rigid frames or slabs that have cover greater than 12 inches, shall be calculated in accordance with the *AASHTO LRFD Bridge Design Specifications*, Article 3.6.2.2.

Dynamic Load Allowance need not be applied to wood components per the *AASHTO LRFD Bridge Design Specifications*, Article 3.6.2.3.

7.2.4.6B The Live Load Impact Factor shall apply to all trucks used in the development of the load rating. Reduction of the Live Load Impact Factor shall not be permitted in determining the safe load carrying capacity of the structure except as follows.

The Impact Factor for concrete arches, rigid frames, or slabs that have greater than 12 inches of fill, shall be applied in accordance with the *AASHTO Standard Specifications for Highway Bridges*, Article 3.8.2.3.

Impact Factor need not be applied to timber components per the *AASHTO Standard Specifications for Highway Bridges*, Article 3.8.1.2.

7.2.4.7 Curb heights greater than or equal to 12 inches shall be considered non-mountable. If a bridge has a non-mountable sidewalk, median, or safety walk that has a width of 6 feet or greater, then the girder supporting that feature shall be rated at the Operating Level for special snow removal equipment using the appropriate load factor, where applicable.

The snow removal equipment shall be assumed to have 2 axles with 2 wheels per axle. The total weight of the snow removal equipment shall be 4 tons (unfactored), divided equally between the 4

wheels, with each wheel load evenly distributed over a tire contact area that is 8 inches wide and 3 inches long. The wheelbase shall be 4 feet and the wheel lines shall be 5 feet apart. The outer wheel line shall be located no closer than 12 inches from the face of railing. The Operating Rating of the supporting members shall be reported in the Breakdown of Bridge Rating and omitted from the Summary of the Bridge Rating.

7.2.4.8 Curbs with height less than 12 inches shall be considered mountable. The beams supporting a mountable sidewalk, mountable median, or mountable safety walk with a width greater than 2 feet measured from the face of the bridge rail to the curb line shall be rated by placing a wheel line 2 feet from the face of the bridge rail. If the above referenced width is 2 feet or less, the wheel line shall be placed 2 feet from the face of the curb. This rating shall be performed at the Operating Level. The Inventory Rating shall always be calculated with the wheel line located in the travelway 2 feet from the face of the curb. Refer to Paragraph 7.2.4.5 for Alternative Load Rating using Actual Lane Location procedures. Refer to Chapter 3, Paragraph 3.5.3.11, Case II for guidance regarding the application of the HL-93 loading for this situation.

7.2.4.9 Pedestrian Load will generally not be included in ratings, unless, based on engineering judgment, its application will produce the maximum anticipated loading. For structural members supporting both sidewalk loads and vehicular traffic, the probability is low for full loading on both the sidewalk and bridge; therefore, only Operating Ratings, including Pedestrian Load, need to be performed. This rating shall be reported in the Breakdown of Bridge Rating and omitted from the Summary of Bridge Rating.

7.2.5 Special Instructions for Load Ratings

7.2.5.1 Any request for clarification of, or deviation from, these guidelines must be submitted in writing (email is acceptable) to the State Bridge Engineer. Written responses will be provided.

7.2.5.2A Condition Factors of the *AASHTO Manual for Bridge Evaluation*, Article 6A.4.2.3 shall not be used in the calculations of the structural capacity. The structural capacity of the section being investigated shall be based on the field conditions.

7.2.5.3A System Factors of the *AASHTO Manual for Bridge Evaluation*, Article 6A.4.2.4 shall be included in the capacity calculations of the non-redundant structure for the section being investigated. Redundant secondary members within a non-redundant structure shall not have their capacities reduced by the same system factor. For example, a bridge comprised of two girders, floorbeams, and stringers shall use a system factor of 0.85 for the girders, 1.0 for the floorbeams, if they are spaced less than or equal to 12 feet, and 1.0 for stringers (refer to Chapter 3, Paragraph 3.6.1.6).

7.2.5.4 Pile bent structures constructed of steel piles, timber piles, or concrete piles, including their pile caps, shall be rated. Other non-reinforced concrete substructures, such as steel frames or substructures that include steel cross girder members, shall also be rated.

Typically, reinforced concrete substructures such as multi-column piers, single column hammerhead piers, solid wall piers and concrete abutments, do not need to be rated because they have sufficient capacity. However, in cases where these types of substructures have undergone deterioration in critical areas that has, in the opinion of the Rating Engineer, reduced their load carrying capacity significantly enough to influence the overall rating of the bridge, then the Rating Engineer shall consult with the MassDOT Ratings and Overload Engineer regarding the need for rating these substructures. This deterioration shall include deterioration of bridge seats and pedestals which has undermined the bridge bearings.

In either case, the report shall contain a statement noting the Rating Engineer's judgment with regards to the substructure.

7.2.5.5 Engineering judgment alone shall not be accepted as a valid method for rating superstructure elements. For structures with unknown structural detail and lack of plans, detailed field measurements, non-destructive testing, and a material testing program shall be performed.

For such situations, a program of material sampling and testing shall be developed and submitted to the State Bridge Engineer for approval prior to performing the testing. All material sampling and testing shall be performed in accordance with the latest ASTM and AASHTO Standards.

7.2.5.6 For structures without the necessary details, such as concrete slabs with unknown reinforcing size and spacing, and with difficult access for the taking of samples as required by Paragraph 7.2.5.5 above, the Rating Engineer shall contact the Bridge Section for guidance.

7.2.5.7 If a beam supporting a raised median rates below statutory levels, the Rating Engineer shall apply the provisions of Paragraph 7.2.4.5 above.

7.2.5.8A All timber structures designed using Load and Resistance Factor Design methodology shall be rated using the Load and Resistance Factor Rating methodology. Where the actual species and grade of lumber are unknown, the Rating Engineer shall determine the species and grade by field observation and/or testing.

7.2.5.8B All timber structures designed using the Allowable Stress Design methodology shall be rated using the Allowable Stress Rating methodology. Where the actual species and grade of lumber are unknown, the Rating Engineer shall determine the species and grade by field observation and/or testing.

The Allowable Inventory Stresses for various timber species and grades, and the appropriate adjustment factors, shall be taken from Section 8 of the *AASHTO LRFD Bridge Design Specifications*. The values used for Allowable Operating Unit Stresses shall be equal to 1.33 times the values determined for the Allowable Inventory Unit Stresses.

7.2.5.9 Tire Contact Area Dimensions. The Tire Contact Area for a given rating vehicle wheel shall be calculated by dividing the reaction of the wheel by an assumed tire pressure of 80 psi. The length of this Tire Contact Area shall be taken as 10" for all vehicle wheels and the width shall be calculated by dividing the calculated Tire Contact Area by this width.

7.2.5.10 BrR can only model parabolic and linear varying web depths for reinforced concrete T-beam superstructures. If a beam's web depth varies along a circular curve, the concrete T-beams can only be modeled in BrR using cross sections and cross-sectional ranges with linear varying web depths.

7.2.5.11 Unless there is a mix formula or design strength given on the plans, concrete for superstructures shall be assumed to have an f'_c equal to 2000 psi for structures built prior to 1931; 3000 psi for structures built between 1931 and 1984; and 4000 psi for structures built after 1984. If a mix proportion is given on the plans, the compressive strengths shall be taken from the 1916 Joint Committee Report as shown in the following Table:

Table 7.2.5-1: Concrete Strengths by Mix Design

Mix	1:1:2	1:1½:3	1:2:4	1:2½:5	1:3:6
f'_c	3000 psi	2500 psi	2000 psi	1600 psi	1300 psi

7.2.5.12 Unless otherwise shown plans, the following shall be used to determine prestressed concrete strengths, f'_c :

Table 7.2.5-2: Prestressed Concrete Strength by Date of Production

	Prior to 1956	1956 - 1985	1985 - 2005 (US Customary Unit projects)	After 1995 (Metric Unit projects)	2005 - Present
f'_c	4000 psi	5000 psi	6000 psi	45 MPa (6526 psi)	6500 psi

In addition, starting with the 2005 Bridge Manual, the use of concrete strengths up to 8000 psi were allowed if approved by the State Bridge Engineer.

7.2.5.13 Unless otherwise shown on the plans, the prestressing strands for prestressed concrete beams shall be assumed to be as follows:

- Prior to 1957: High tensile strength wire or high tensile strength seven wire strand.
- 1957 to 1987: ASTM A 416 Uncoated Seven-Wire Stress Relieved strands.
- After 1987: AASHTO M203 (ASTM A 416) Uncoated Seven-Wire Stress Relieved Low Relaxation (Lo-Lax) strands.

Table 7.2.5-3: Prestressed Strand Strength by Date of Production

	Prior to 1957 Wire	Prior to 1957 7 Wire Strand	1957 - 1970	1970 - 1987	After 1987
Ultimate Strength	236 ksi	250 ksi	250 ksi	270 ksi	270 ksi

7.2.6 Special Instructions for Load Ratings of Prestressed Concrete Members including Adjacent Prestressed Concrete Beams

7.2.6.1 Unless there is physical evidence that the grouted keyway(s) between adjacent prestressed concrete beams are not transferring shear, all loads applied to the adjacent beam bridge cross section shall be distributed assuming the beams function together as a unit.

7.2.6.2B The Allowable Stresses at Inventory Levels for prestressed concrete members shall be calculated using the formulas presented in the *AASHTO Manual for Bridge Evaluation*, Article 6B.5.3.3. The formulas for the prestressing steel rating presented in this Article need not normally be checked for either the Inventory or Operating Stress Levels. The only situation these rating values might control a rating would be in the unlikely case of very lightly prestressed members. All Allowable Stress values used in the preparation of the rating report must be clearly stated in the Rating Analysis Assumptions and Criteria section of the rating report.

The *AASHTO Manual for Bridge Evaluation* provides one set of rating factor formulas for the rating of prestressed concrete members that consider both strength and serviceability together. Therefore, when calculating the Load Factor Rating of prestressed concrete members, the flexural and shear strength rating factors for both Inventory and Operating Levels shall be obtained using the formulas as specified in Article 6B.5.3.3 of the *AASHTO Manual for Bridge Evaluation*. The rating factor formulas

make no provisions for serviceability for Operating Ratings and thus serviceability Operating Rating values need not be calculated.

7.2.7 Special Instructions for Load Ratings of Stone Masonry Arches

7.2.7.1 The *AASHTO Manual for Bridge Evaluation*, Article 6A.9.1 states that unreinforced stone masonry arches should be evaluated by the Allowable Stress Method. An acceptable method of analysis is outlined below.

7.2.7.2B The arch shall be modeled using a series of prismatic two-noded beam elements, with the loads applied at each node or as linearly varying loads to each element. A minimum of 10 straight beam elements or 1 straight beam element per 4 feet of clear span, whichever results in the most elements, shall be used. Each element shall be of equal arc length. The node locations shall correspond to the mid-depth points of the arch segments. The arch geometry used in the analysis shall be determined using either a parabolic, circular, elliptical, or fifth order polynomial curve that achieves the best fit with the actual arch. Field measurement and confirmation of the arch geometry is critical. Assuming an arbitrary geometry is not acceptable since it may result in inaccurate results.

7.2.7.3B Vertical dead loads shall be calculated along the horizontal length of each element and shall be applied as linearly varying loads to each element. The height of fill shall be computed from the extrados to the bottom of the wearing surface.

7.2.7.4B The dead load of sidewalks, wearing surfaces, railings, curbs, and spandrel walls shall be computed and equally distributed across the width of the arch. In some cases, the spandrel wall can function as an independent member capable of supporting its self-weight and perhaps a portion of the arch. However, the ability of a spandrel wall to support itself and a portion of the arch is uncertain and shall be neglected in the analysis.

7.2.7.5B The horizontal earth pressure loads shall be calculated assuming a lateral earth pressure coefficient of 0.25. The loads shall be computed along the vertical heights of each element and shall be applied as linearly varying loads to each element.

7.2.7.6B Load ratings of stone masonry arches need not consider thermal effects.

7.2.7.7B Unit loads shall be applied to each node in the model to generate influence coefficient tables and lines for moment, shear, and axial load at given nodes. Extreme care shall be exercised to ensure that proper sign convention is maintained. From these influence lines, the maximum moment and corresponding shear and axial loads shall be calculated. At a minimum, influence lines shall be developed at the springlines, crown, quarter points, and at points where significant changes in section properties occur.

7.2.7.8B Live loads shall be positioned in such a way so as to maximize the moment at each node. It may be helpful to superimpose a transparent wheel load pressure umbrella over a scaled longitudinal section that depicts the wearing surface and arch extrados. The objective is to load those elements so that live load moment shall be maximized at nodes of interest.

7.2.7.9B In the load rating of stone masonry arches, the maximum eccentricity shall be calculated in order to determine the critical node locations. The eccentricities shall be calculated by dividing the combined dead and live load moments by the combined dead and live load thrusts.

7.2.7.10B In the load rating of stone masonry arches, the concept of a "kern" or middle third section is used to determine whether any portion of the masonry is in tension. The kern points are located above

and below the neutral axis of the arch at a distance r^2/c , where “r” is the radius of gyration and “c” is the distance from the neutral axis to the extreme fiber.

In cases where the combined dead and live load thrust falls outside the kern points, resulting in tension in the masonry, a pressure wedge analysis shall be used to calculate the maximum compressive stress. The portion of the arch masonry in tension shall be effectively ignored by redistributing the pressure over a smaller depth.

If the eccentricity (e) of the combined thrust is located below the bottom kern point, the maximum compressive stress shall be determined as follows:

$$\begin{aligned} f_t &= 0 \text{ (no tension assumed at top of masonry)} \\ f_b &= (P/A)(d/c) = (P/A)(d/(d/2)) = 2P/A \end{aligned}$$

Where:

$$\begin{aligned} e &= \text{Combined Moment/Combined Thrust} \\ f_t &= \text{Stress at the top of the section} \\ f_b &= \text{Stress at the bottom of the section} \\ P &= \text{Compressive reaction} \\ A &= 3(d/2-e)(\text{Unit Width}) \\ d &= \text{Depth of Arch Section} \\ c &= \text{Distance from neutral axis to extreme fiber} \end{aligned}$$

If the eccentricity (e) of the combined thrust is located above the top kern point, the maximum compressive stress shall be similarly determined as follows:

$$\begin{aligned} f_t &= (P/A)(d/c) = (P/A)(d/(d/2)) = 2P/A \\ f_b &= 0 \text{ (no tension assumed at bottom of masonry)} \end{aligned}$$

If the eccentricity (e) of the combined thrust is located between the kern points, the maximum compressive stress shall be determined as follows:

$$f_b \text{ or } f_t = (P/A)(1 + 6e/d)$$

Where:

$$A = \text{Cross sectional area}$$

7.2.7.11B The Inventory Allowable Compressive Stresses for stone masonry shall be determined in accordance with Article 6B.5.2.6 of the *AASHTO Manual for Bridge Evaluation*. Professional judgment based upon field observations and testing is pivotal to the proper determination of Inventory Allowable Compressive Stresses for stone masonry. Based upon the Rating Engineer's judgment, Allowable Compressive Stresses may be lowered for low quality masonry, or raised, if justified by testing of samples taken from the bridge. Ratings for stone masonry arches shall only be provided at the Inventory Stress Level. Ratings for the EV2 and EV3 vehicles shall also be calculated at the Inventory Stress Level but reported at both Inventory and Operating Stress Levels for this type of structure. Report the same values for Items 64 and 66.

7.2.7.12 Since the applied loading to the arch affects the eccentricities of the element compression forces, an iterative process must be used to determine the load ratings. It is not permissible to simply use the rating factor that is calculated from the applied Rating Vehicle loadings and multiply it by the vehicle tonnage. This iterative process shall be used for rating factors above and below 1.0 for all Rating Vehicles. The following procedure shall be used to develop the ratings for the arch:

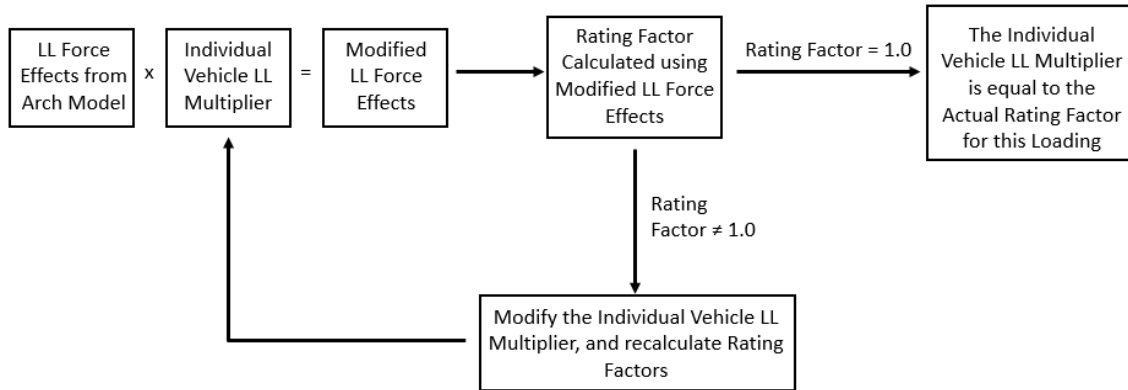

Figure 7.2.7-1: Stone Masonry Arch Rating Procedure Flow Chart

1. Analyze the arch for the Rating Vehicles to obtain dead and live load effects used to rate the arch.
2. Perform a preliminary load rating per the steps outlined above. Rating factors not equal to 1.0 will need to be refined to determine the gross tonnage for the structure.
3. Create a “live load effect multiplier” specific for each vehicle which will factor the live load axial forces and bending moments prior to re-rating the arch elements (dead loads will not be modified).
4. Increase or decrease the live load effect multipliers individually for each vehicle until the rating factors equal 1.0. When this is achieved, the load effect multiplier will be equal to the actual rating factor of the arch for that vehicle.

7.2.8 Special Instructions for Load Rating of Reinforced Concrete Arches

7.2.8.1A Concrete arches designed in accordance with LRFD shall be rated in accordance with *AASHTO LRFD Bridge Design Specifications* and the LRFR provisions of the *AASHTO Manual for Bridge Evaluation*.

7.2.8.1B The combined axial load and moment capacities of reinforced concrete arches shall be determined in accordance with Article 8.15 of the *AASHTO Standard Specifications for Highway Bridges*. Interaction diagrams for combined flexural and axial load capacities shall be produced, for reference see the *AASHTO Manual for Bridge Evaluation*, Appendix G6A. Inventory Capacities shall be obtained by using 35% of the capacities determined in accordance with Article 8.15.4 of the *AASHTO Standard Specifications for Highway Bridges*. Operating Capacities shall be obtained by using 50% of the capacities determined in accordance with this same Article.

7.2.8.2B The *AASHTO Manual for Bridge Evaluation*, states that environmental loads, in combination with dead and live load effects, shall be included at the Operating Level. Load ratings of concrete arches with spans greater than 100 feet shall consider thermal loading at the Operating Level.

7.2.8.3B While load rating reinforced concrete arches, especially pre-engineered arches or frames, the Rating Engineer shall be aware that the design may have incorporated the soil/arch interaction to reduce the forces in the arch. This soil/arch interaction shall be considered in the development of the rating report.

7.2.9 Special Instructions for Load Rating of Corroded Steel Beam Webs

7.2.9.1 Corrosion of steel beam webs due to exposure to deicing chemicals is a very common problem that must be addressed in load ratings. This deterioration is typically located below leaking deck joints and consists of reduced web thicknesses and irregularly shaped web holes in advanced cases. This may result in web local yielding, web local crippling, or other inelastic responses in beam ends. When web section losses within the bottom 4" of the web height equal or exceed an average of 1/8" over that height, the simplified methods presented in the following sections shall be used to establish load ratings.

Note that the following checks are supplemental ratings that are performed in addition to the typical limit states, in particular for shear. If a corroded beam needs to be rated according to this section, it is recommended that the shear rating for the beam also be included in the Breakdown of Bridge Rating, regardless of whether or not it controls the overall rating for the beam.

7.2.9.2 Based on typically observed beam-end deterioration, as well as the anticipated failure mechanism, nominal capacities shall be determined based on the average remaining thickness of the web within the bottom 4" of the web height. Any holes shall be considered ineffective for the full 4" height. Engineering judgement shall be used in situations where advanced section loss occurs outside of the 4" height.

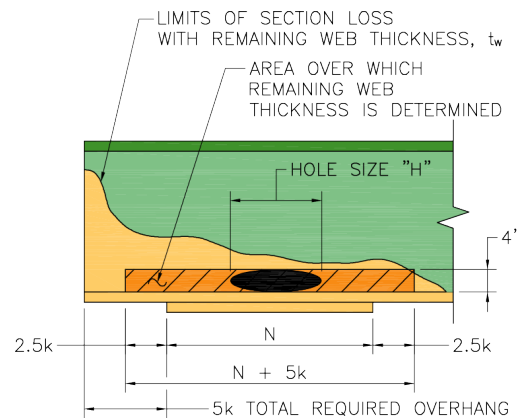

Figure 7.2.9-1: Graphic for Corroded Steel Beam Webs

Previous editions of this Bridge Manual included a check of the buckling capacity at beam ends where advanced corrosion had occurred. It was found that often this check was very conservative and not representative of the actual failure mechanism. This is typically the result of the presence of concrete encased end diaphragms; localized corrosion along bottom of the web, rather than over the full height; conservative boundary conditions, ignoring that the web is supported along three sides; and neglecting the length of the bearing, among other factors. Therefore, this check has been deleted. This section has been further revised based on the completion of research performed by UMass for MassDOT. The remaining provisions of these Subsections have been revised based on the final report, which may be found here:

https://www.mass.gov/files/documents/2019/11/13/BeamEndsFinalReportOct_2019.pdf

It shall be noted that additional revisions to the approach have been made following issuance of the final report. These revisions are not readily available online.

The UMass research developed these current provisions through extensive finite element modeling, which was calibrated through testing of simple span ends of deteriorated beams. The beams were single beam segments without diaphragms, stiffeners, or a slab. The prior provisions were based on the *AISC Steel Construction Manual* for similar, while non-deteriorated, end conditions.

Also note, that based on the tests, that these capacities are often achieved with a large amount of deformation of the section. This is especially true when the section losses at the end exceeded 65% of the original section.

When determining what section loss to apply to the beam for regular shear capacity (BrR input), a weighted average over the entire beam depth shall be used. For example, if the bottom half of a beam web has 50% section loss, the overall deterioration input will be 25%. This approach shall not be used when considering these local effects.

7.2.9.3 The nominal web beam end capacities for beam ends with section loss and without bearing stiffeners shall be calculated using the following procedure.

The resistance factors for the LRFD method are as given in the *AASHTO LRFD Bridge Design Specifications*, whereas the Allowable Stress safety factors (Ω) are from the *AISC Steel Construction Manual* and are used for the Inventory level capacities. The Operating safety factor is taken as the Inventory safety factor multiplied by 55/75. For Load Factor Ratings the safety factors (Ω) are modified as described in Paragraph 7.2.9.4B.

The nominal web local yielding capacity, in kips ($R_{n,(1)}$) shall be determined from the minimum value calculated as follows:

For beam ends without bearing stiffeners, the average web thickness, t_{ave} , used for beam-end deterioration analysis at end supports with a beam overhang of at least 5k, shall be based on the equation below. If an overhang past the bearing of less than 5k is provided, then the “5k” term in the equation shall be substituted with “2.5k”.

$$t_{ave} = \frac{(N + 5k - H) * t_w}{(N + 5k)}$$

Where:

t_{ave}	=	average remaining web thickness (in.)
N	=	bearing length (in.)
k	=	distance from outer face of flange to toe of web fillet for a rolled shape, or toe of web to flange weld for a plate girder (in.)
H	=	total length of hole(s) along length used for capacity within (N+5k or N+2.5k) (in.)
t_w	=	remaining web thickness (in.)

At beam end reactions where an overhang past the bearing of at least 5k is provided

$$R_{n,(1)} = F_y t_{ave} (5k + N)$$

At beam end reactions where an overhang of less than 5k is provided

$$R_{n,(1)} = F_y t_{ave} (2.5k + N)$$

Where:

$R_{n,(1)}$	=	nominal web local yielding capacity (kips)
F_y	=	minimum yield strength (ksi)

- t_{ave} = the average remaining thickness within the bottom 4" of the web height (in.)
- k = distance from outer face of flange to toe of web fillet for a rolled shape, or toe of web to flange weld for a plate girder (in.)

The nominal web beam end capacity, based on the UMass equation, in kips ($R_{n,(2)}$) shall be calculated as follows:

For beam ends without bearing stiffeners, the average web thickness, t_{ave} , used for beam-end deterioration analysis at end supports shall be based on the equation below. The UMass study determined that one of the controlling factors regarding beam end capacity is the initial imperfection amplitude, the amount that the web is out of plane. This amplitude is measured as a fraction of the original web thickness, i.e. $1 t_{web}$. Imperfection Amplitude is equal to 1 web thickness out of plane. MassDOT's Inspection section has been made aware that this value has become critical to determining the capacity, and is developing procedures to measure this value. When these measurements are not available in the inspection report the Rating Engineer shall assume the values associated with $0.5 t_{web} \geq i > 0.1 t_{web}$. However, the Rating Engineer shall review the report to ensure that there are no imperfections clearly exceeding the $0.5 t_{web}$ limit.

$$t_{ave} = \frac{(N + m d - H) * t_w}{(N + m d)}$$

Where:

- t_{ave} = average remaining web thickness (in.)
- N = bearing length (in.)
- m = factor specified in Table 7.2.9-1
- d = beam depth (in.)
- H = total length of hole(s) along length used for capacity within $(N + m d)$ (in.)
- t_w = remaining web thickness (in.)

Table 7.2.9-1: Values of Factor (m) - for Average Web Thickness Calculation

	Imperfection Amplitude (i)*		
	$i > 0.5 t_{web}$	$0.5 t_{web} \geq i > 0.1 t_{web}$	$i \leq 0.1 t_{web}$
$N/d > 0.2$	0.2	0.2	0.1
$N/d \leq 0.2$	0.1	0.1	0.0

*Values shall not be interpolated

For beam end reactions when $N/d > 0.2$

$$R_{n,(2)} = \left(a \sqrt{EF_y t_f} t_{ave}^{1.5} + b \frac{(0.33d)}{N} \left(\frac{4(N-H)}{d} - 0.2 \right) \frac{\sqrt{EF_y t_f}}{t_{ave}^{1.5}} t_{ave}^3 \right) \left(\frac{CL}{(N+m d)} \right)^{0.15}$$

Where:

- $R_{n,(2)}$ = nominal web beam end capacity, based on the UMass equation (kips)
- E = elastic modulus of steel (ksi)
- F_y = yield strength of steel (ksi)
- t_f = bottom flange thickness (in.)
- t_{ave} = average remaining web thickness (in.)

- b = factor specified in Table 7.2.9-2
 N = bearing length (in.)
 H = total length of hole(s) along length used for capacity within (N + m d) (in.)
 CL = Corrosion length within length over which average remaining web thickness is determined (in.) CL shall not be less than N/2. For smaller corrosion lengths, use a minimum of N/2. (CL_{minimum} = N/2)
 m = factor specified in Table 7.2.9-1

Table 7.2.9-2: Factors for Calculating $R_{n(2)}$ when $N/d > 0.2$

	Imperfection Amplitude (i)*		
	$i > 0.5 t_{web}$	$0.5 t_{web} \geq i > 0.1 t_{web}$	$i \leq 0.1 t_{web}$
a	0.37	0.32	0.57
b	0.17	0.50	0.23

In *Values shall not be interpolated

For beam end reactions when $N/d \leq 0.2$

$$R_{n(2)} = \left(a \sqrt{EF_y t_f} t_{ave}^{1.2} + b \left(\frac{N-H}{d} \right) \sqrt{\frac{EF_y t_f}{t_f^{1.5}}} t_{ave}^3 \right) \left(\frac{t_{ave}}{t_{web}} \right)^h$$

Where:

- $R_{n(2)}$ = nominal web beam end capacity, based on the UMass equation (kips)
 E = elastic modulus of steel (ksi)
 F_y = yield strength of steel (ksi)
 t_f = bottom flange thickness (in.)
 t_{ave} = average remaining web thickness (in.)
 N = bearing length (in.)
 H = total length of hole(s) along length used for capacity within (N + m d) (in.)
 d = beam depth (in.)

Table 7.2.9-3: Factors for Calculating $R_{n(2)}$ when $N/d \leq 0.2$

	Imperfection Amplitude (i)*		
	$i > 0.5 t_{web}$	$0.5 t_{web} \geq i > 0.1 t_{web}$	$i \leq 0.1 t_{web}$
a	0.33	0.32	0.38
b	0.00	0.17	0.00
h	0.40	0.20	0.15

7.2.9.4A The corroded web rating at both the Inventory and Operating levels shall be determined using the minimum of the factored resistances from the calculated nominal web beam end capacities as follows:

$$\text{Corroded Web Factored Resistance, } \Phi R_n = \text{Min} [\Phi R_{n(1)}, \Phi R_{n(2)}]$$

Where:

- $\Phi R_{n(1)} = (\Phi_b = 1.0)(R_{n(1)})$
 $\Phi R_{n(2)} = (\Phi_b = 0.8)(R_{n(1)})$

Rating Factor:

$$\text{LRFR Rating Factor} = \frac{\Phi R_n - DL_{rxn}}{(L + I)_{rxn}}$$

7.2.9.4B The corroded web rating at both the Inventory and Operating levels shall be determined using the minimum of the calculated nominal web beam end capacities as follows:

For Allowable Stress Ratings:

$$R_{all,(1)} = \left[\frac{1}{(\Omega = 1.8)} \right] (R_{n,(1)})$$

$$R_{all,(2)} = \left[\frac{1}{(\Omega = 2.4)} \right] (R_{n,(2)})$$

$$\text{Corroded Web Inventory Capacity} = \text{Min} [R_{all,(1)}, R_{all,(2)}]$$

$$\text{Corroded Web Operating Capacity} = (75/55) * \text{Min} [R_{all,(1)}, R_{all,(2)}]$$

For Load Factor Ratings:

$$R_{all,(1)} = \left[\frac{1}{(\Omega = 1.0)} \right] (R_{n,(1)})$$

$$R_{all,(2)} = \left[\frac{1}{(\Omega = 1.0)} \right] (R_{n,(2)})$$

$$\text{Rating Factor} = \frac{\text{Min} [R_{n,(1)}, R_{n,(2)}] - A_1 * DL_{rxn}}{A_2 * (L + I)_{rxn}}$$

Note: For Load Factor Ratings, apply the appropriate load factors to DL_{rxn} and $(L + I)_{rxn}$.

7.2.9.5 For beam ends with bearing stiffeners, the web local yielding capacity (R_{yield}) shall be calculated using the following derived resistances. This section, originally developed based on the provisions of the *AASHTO LRFD Bridge Design Specifications* has been further revised based on the completion of research performed by UMass for MassDOT. The remaining provisions of these Subsections have been revised based on the final report, which may be found here:

<https://www.mass.gov/doc/improved-load-rating-procedures-for-deteriorated-steel-beam-ends-with-deteriorated-stiffeners-final-report/download>

The UMass research developed these current provisions through extensive finite element modeling, which was calibrated through testing of simple span ends of deteriorated beams. The beams were single beam segments without diaphragms or a slab.

When determining what section loss to apply to the beam and stiffener for regular shear capacity (BrR input), a weighted average over the entire beam and/or stiffener depth shall be used. For example, if the bottom half of a beam web has 50% section loss, the overall deterioration input will be 25%. For the stiffener input, the section thickness in BrR will need to be reduced to model the deterioration. This approach shall not be used when considering these local effects.

The current provisions completely supersede the prior provisions, providing an empirical formula with associated parameters determined from the corrosion patterns defined as follows.

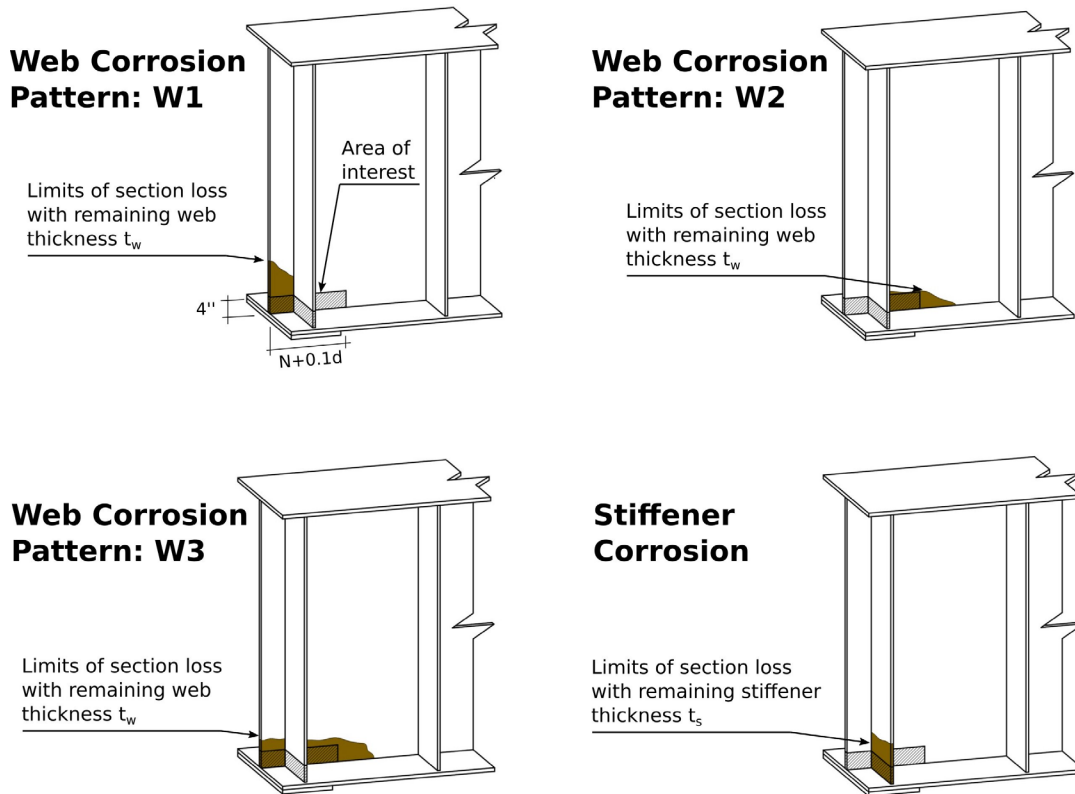

Figure 7.2.9-2: Corrosion Patterns for Determining Parameters to be used in Empirical Equation

7.2.9.6 The nominal beam end capacity for beam ends with section loss and with bearing stiffeners shall be calculated using the following procedure.

The resistance factors for the LRFD method are as given in the *AASHTO LRFD Bridge Design Specifications*, whereas the Allowable Stress safety factors (Ω) are from the *AISC Steel Construction Manual* and are used for the Inventory level capacities. The Operating safety factor is taken as the Inventory safety factor multiplied by 55/75. For Load Factor Ratings the safety factors (Ω) are modified as described in Paragraph 7.2.9.7B.

A key observation emerging from the computational work of the research is in regard to the dimensions of the damaged area that significantly affect the remaining capacity of the corroded beams. A corroded area that extends beyond 10% of the web and stiffener height or beyond 10% of the bearing length does not further significantly decrease the girder strength. To incorporate this finding, the length of the web over which the A_{web} is calculated is modified from $N+2.5k$ to $N+0.1d$. The web and stiffener region that is located at the bottom 4 in. of the beam, extending longitudinally from the outer bearing edge to 10% beyond the bearing length is the area of concern. Accounting for holes in the web or the stiffeners, within the area of interest, A_{web} , and A_{stif} are defined as follows:

$$A_{web} = t_w (N + 0.1d_w) - \sum \text{Web Hole Areas}$$

Where:

A_{web} = Cross Sectional Area of web used to calculate beam end capacity (in.²)

- t_w = remaining web thickness for corrosion pattern as defined in Fig. 7.2.9-2 (in.)
 N = bearing length (in.)
 d_w = depth of web (in.)

$$A_{stif} = 2t_s b_s - \sum \text{Stiffener Hole Areas}$$

Where:

- A_{stif} = Cross Sectional Area of stiffeners used to calculate beam end capacity (in.²)
 t_s = remaining stiffener thickness within the bottom 4 in. of the beam (in.)
 b_s = stiffener width (in.)

The nominal beam end capacity, in kips ($R_{n,(3)}$) shall be calculated as follows:

$$R_{n,(3)} = \left(a F_y A_{stif} + b (F_y A_{web})^c \right)$$

Where:

- A_{stif} = Cross Sectional Area of stiffeners used to calculate beam end capacity (in.²)
 A_{web} = Cross Sectional Area of web used to calculate beam end capacity (in.²)

Table 7.2.9-4: Parameters Based on Corrosion Pattern for $R_{n,(3)}$ Equation

	Corrosion Pattern		
	W1	W2	W3
a	1.33	1.46	1.00
b	0.55	1.16	0.21
c	1.48	0.93	1.23

7.2.9.7A The corroded web rating at both the Inventory and Operating levels shall be determined as follows:

For Load and Resistance Factor Ratings:

$$\Phi R_{n,(3)} = (\Phi_b = 1.0)(R_{n,(3)})$$

Rating Factor:

$$\text{LRFR Rating Factor} = \frac{\Phi R_{n,(3)} - DL_{rxn}}{(L + I)_{rxn}}$$

7.2.9.7B The corroded web rating at both the Inventory and Operating levels shall be determined as follows:

$$\begin{aligned}
 \text{Corroded Web Inventory Capacity} &= R_{n,(3)} \\
 \text{Corroded Web Operating Capacity} &= (75/55) * R_{n,(3)}
 \end{aligned}$$

For Allowable Stress Ratings:

$$R_{all,(3)} = \left[1/(\Omega = 1.5) \right] (R_{n,(3)})$$

For Load Factor Ratings:

$$R_{all,(3)} = \left[1 / (\Omega = 1.0) \right] (R_{n,(3)})$$

$$\text{Rating Factor} = \frac{R_{all,(3)} - A_1 * DL_{rxn}}{A_2 * (L + I)_{rxn}}$$

Note: For Load Factor Ratings, apply the appropriate load factors to DL_{rxn} and $(L + I)_{rxn}$

7.2.10 Special Instructions for Load Rating of Deteriorated Prestressed Beams

7.2.10.1 Concrete deterioration and loss of prestressing is a significant issue in the load rating of prestressed concrete beams. This issue is of particular concern with adjacent box and deck beam bridges, as these structures are impossible to completely inspect, with only the bottom flange and the exterior web of the fascia beams visible and available for tactile inspection. However, in many instances evidence of leakage of salt laden roadway runoff through the grouted joints is visible, indicating possible deterioration of unknown levels in locations unavailable for inspection.

Often this deterioration will progress to the underside of the beam (bottom flange), spalling off large pieces of concrete and exposing the prestressing strands to the environment, eventually leading to their deterioration. There is no uniformly accepted guidance on how to estimate loss of prestressing force, if any, and its effect on load carrying capacity.

The following guidelines for calculating a reduced prestressing force are based primarily upon research conducted by the University of Illinois at Urbana-Champaign and Illinois DOT (IDOT), augmented with MassDOT experience, and are to be used in evaluating prestressed concrete beams. Refer to Figures 7.2.10-1 and 7.2.10-2 below for guidance.

7.2.10.2 In the vicinity of exposed reinforcing steel stirrups deduct 100% of the strand area located in the bottom row directly above the limits of the exposed stirrups. Deduct 25% of the area of the strands in the next row directly above the limits of the exposed stirrups. Deduct 25% of the area of the strand(s) in the bottom row next to the area of the exposed reinforcing stirrups.

7.2.10.3 In the vicinity of exposed prestressing strands deduct 100% of the strand area within the limits where they are exposed. Deduct 50% of the area of the strands in the next row directly above the limits of the exposed strands. Deduct 50% of the area of the strand(s) in the bottom row next to the limits of the exposed prestressing strands.

7.2.10.4 In areas of concrete delamination without exposed reinforcing stirrups or prestressing strands deduct 50% of the area of the prestressing strands located in the row directly above the limits of the delamination. Deduct 10% of the area of the prestressing strand(s) in the bottom row next to the limits of the delamination.

7.2.10.5 A longitudinal crack shall be considered to be a delamination that is six inches wide centered on the crack. The length of the delamination shall be the length of the crack plus six inches at each end of the crack. The loss of prestressing force at this theoretical delamination shall be calculated in accordance with Paragraph 7.2.10.4 above.

7.2.10.6 The reduced prestressing force due to losses as calculated in the paragraphs above shall only apply to the area of the deterioration. Outside of these areas, all prestressed strands shall be assumed to be 100% effective and shall be appropriately re-developed into areas of sound concrete. For example, a strand with 100% loss will require 100% of its development length before it is considered fully

effective again. Likewise, a strand with 50% section loss will require 50% of its development length, in sound concrete, before it is fully effective again.



Figure 7.2.10-1: Example of Spalls and Delamination

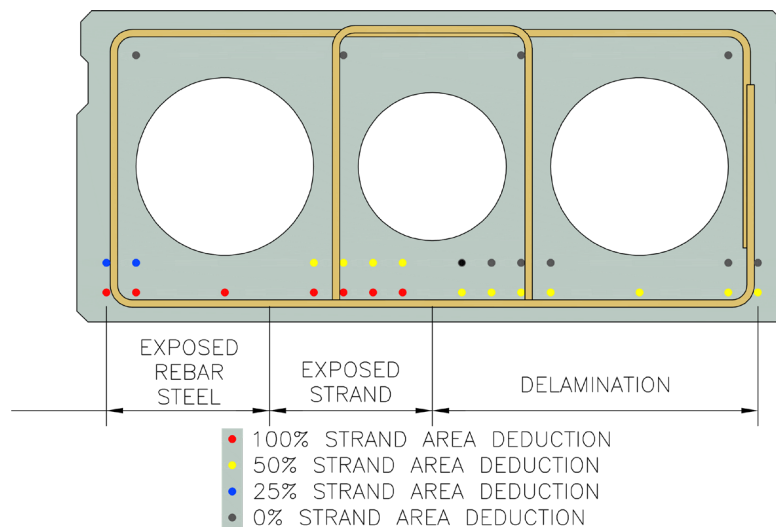

Figure 7.2.10-2: Deck Beam Cross-Section (see Figure 7.2.10-1)

7.2.11 Guidelines for Preparing the Evaluation of Rating and Recommendations

7.2.11.1 Evaluation of Rating. The Rating Engineer shall summarize the controlling elements of the structure that the Summary of Rating is based on. The Rating Engineer shall also explain the reason for any significant differences between the current rating results and those of the previous rating, especially if the current rating values are much greater. Since a bridge should not experience a large gain in strength with age, this evaluation should also prompt a review of the of the analysis methods and assumptions as well as a review of the computer model used and rating software results for any potential errors. Similarly, the rating analysis methods, assumptions, software, etc. shall be reviewed if a rating has reduced significantly without notable section loss or added weight.

7.2.11.2 Recommendations. The Rating Engineer shall make recommendations for either improving or maintaining the condition of the structure. The Rating Engineer may also make general or specific recommendations to address a structural deficiency or to improve the load carrying capacity of the

bridge. Such recommendations shall be based on sound engineering judgment and the results of the rating analysis. The Rating Engineer must examine all ramifications of such recommendations so that any recommendation included in the rating report is feasible, safe and shall not adversely affect the structure or its long-term performance and maintainability.

The Rating Engineer is cautioned against making unrealistic or impractical recommendations just for the sake of making a recommendation. Any specific recommendation that may alter the bridge's load carrying capacity shall include rating calculations, located in Appendix C of the Report, that shall indicate the revised rating if the recommendation is implemented. For example, if temporary concrete barriers are recommended to restrict live load from an exterior beam, the effect of the added dead load shall be considered in the rating of the interior beams.

7.2.11.3 Recommendations for Immediate Action. If the Rating Engineer considers that addressing the condition of the bridge structure or its load carrying capacity requires immediate action, they are obligated to inform the State Bridge Engineer as soon as possible and not wait for the report to be completed and submitted.

7.3 REPORT SUBMITTAL REQUIREMENTS

7.3.1 Submittal Requirements

7.3.1.1 Review Submission. An initial submission for review shall be made which satisfies all the subsequent requirements for a Load Rating Report, except that this review submission does not require the Rating Engineer's stamp or signature. The Independent Reviewer shall still sign and date, but not stamp, the Statement of Concurrence and include a completed Rating Checklist to provide assurance that the report has been reviewed prior to submission. Following an initial review and approval of the Ratings and Overloads Unit, the Rating Engineer shall provide a final stamped, signed, and dated submittal which shall also include the stamp, signature, and date of the signature of the Independent Reviewer, and a completed Rating Checklist. Should the initial submittal require revisions due to comments provided by the Ratings and Overloads Unit, these comments shall be resolved and a revised initial submittal provided if necessary, for subsequent review and approval or comment prior to the final stamped, signed, and dated submittal.

7.3.1.2 Electronic Submissions. The entire report shall be submitted as an electronic file in PDF format either via email or through file sharing to MassDOTLoadRatingSubmittals@dot.state.ma.us. The first and last page of the PDF ("covers") shall be color-coded as follows: RED, if the rating for any posting vehicle is 6 tons or less; YELLOW, if more than 6 tons but less than statutory; and GREEN for statutory or greater. The front cover and title page shall be formatted in accordance with Figure 7.5.2-1.

The names of Facility Carried / Feature Intersected and the Memorial Name/Local Name must be exactly the same as those given on the SI&A with the following exceptions. The generic Feature and/or Facility Codes (i.e. WATER, HWY, RR, etc.) shall be omitted, but the Interstate (I-), US Route (US) and State Route (ST) code along with the route number, and direction if applicable (NB, SB, etc.), followed by the local street names (if any) in parentheses, shall be provided. The local street names shall be fully spelled out (e.g. N WSHNGTN ST on the SI&A shall be spelled out as North Washington Street). If the same stretch of road has several numbered routes associated with it, then all of the routes shall be provided separated by a slash (/) starting with the Interstate, then the US Route, then the State Route, then followed by the local street name (if any) in parentheses. The following are examples of the proper identification of the bridge with some common Facility Carried/Feature Intersected:

- *ST 19 (WALES ROAD) OVER MILL BROOK*
- *ST 20A (PLAINFIELD STREET) OVER I-91 NB*
- *US 202 (GRANBY ROAD) OVER ST 116 (NEWTON STREET)*
- *I-95/US 1/ST 3 OVER WEST STREET*
- *ST 31 (RESERVOIR STREET) OVER PROVIDENCE & WORCESTER RR*
- *WOLOMOLOPOAG STREET OVER AMTRAK/MBTA*

The files in the electronic submission shall be organized in the following four folders:

- **COMPUTER INPUT FILES:** all BrR and/or other MassDOT approved rating analysis software input files that were used to produce the rating
- **CALCULATION FILES:** the spreadsheets and other computer calculation aids that were used to develop the rating
- **RATING REPORT:** the Rating Report itself formatted as specified in Section 7.5
- **BRIDGE PLANS:** all plans of the bridge that were made available to the Rating Engineer for the preparation of the Rating Report

7.3.2 Report Distribution

The electronic submission shall be made with email and attachments or via a file sharing link sent to the Bridge Section at MassDOTLoadRatingSubmittals@dot.state.ma.us.

7.3.3 Checklist

A separate Bridge Load Rating Report Checklist file shall be provided with each rating submission. Note, that any item in the checklist noted with FATAL OMISSION that is responded to with a NO (N) response will result in an automatic rejection of the rating without any further review by the Bridge Section.

7.4 CALCULATIONS AND INPUT FILE FORMAT

7.4.1 Hand and Electronic Calculations

7.4.1.1. All submitted hand calculations shall include either sketches or copies of the necessary sheets or details from the plans to support the calculations being prepared. All hand calculations shall include all details along with relevant notes and code references so that every step of the calculations can be easily followed, in a logical order, legible and prepared on 8 ½" x 11" paper that is subsequently scanned for inclusion in the submission file.

7.4.1.2 Calculations using spreadsheets and other computer calculation aids (e.g. Mathcad) shall be formatted and presented as hand calculations and formatted to allow for printing on 8½" x 11" paper without scaling. These computer aided calculations shall be presented in a logical order along with relevant notes and code references so that every step of the calculations can be easily followed. Copies of the original calculation files shall be included with the submission as described in Subsection 7.3.1. For example, spreadsheets, and other similar formats, shall be appropriately documented with references and organized so that the calculations in them can be easily followed by an independent

reviewer. Calculations shall be organized by name or in folders so that an independent reviewer can determine how each file is intended to be used. An index identifying each file by name with a brief explanation shall be provided. Naming of calculation files shall not include excessive description since file and folder character limitations can cause errors resulting in incomplete archiving of submissions.

7.4.2 BrR Input File Submission

7.4.2.1B The Rating Engineer shall prepare the BrR file in a manner that will allow MassDOT to analyze the structure using the LRFR method at a later date.

7.4.2.2 BrR shall be used to rate every primary load carrying element of the structure in order to determine the controlling live load capacity of the structure. The bridge shall be modeled as a Girder System, wherever possible. Links shall be used to define identical girders within a girder system. However, the following member types shall be modeled as described below:

1. When the structure is a concrete slab bridge it shall be modeled as a Girder Line;
2. When the exterior beam acts composite with a sidewalk or a safety curb, this particular member shall be modeled as a Girder Line and the remaining portion of the structure shall be modeled as a Girder System;

7.4.2.3 The file naming convention for the BrR file shall be consistent with the following Massachusetts specific example of a Town Line bridge:

Bridge No. D-02-033=P-15-015, BIN = BG1, DANA-PRESCOTT, MAIN STREET / SWIFT RIVER shall be identified without any blank spaces using the following UPPER CASE characters:

Bridge ID (unlimited characters):	D-02-033=P-15-015 (BG1)
NBI Structure ID (NBI Item 8, 15 characters):	D02033BG1DOTNBI
Name (same as Bridge ID):	D-02-033=P-15-015 (BG1)
Description (unlimited characters):	2 SPAN SIMPLE COMPOSITE MULTIPLE STEEL STRINGER <i>(Modify as required.)</i>

Where:

The first 13 characters (22 if town line bridge, as shown in the example) reflect the structure's Bridge Number, including hyphens, equal sign, and parentheses, and the characters within the parentheses represent the structure's BIN.

For submission purposes, the file shall be exported with the extension .XML:

D-02-033=P-15-015(BG1).XML

7.4.2.4 All relevant information from the structure SI&A sheet shall be transcribed verbatim into the available fields in the BrR file's Bridge Workspace Window.

7.4.2.5 Calculations for all loads and distribution factors shall be clearly shown within the rating. All dead loads and live distribution factors shall be summarized in a table provided at the start of Appendix C.

7.4.2.6 Summary of non-composite dead loads, which may include, but not be limited to, diaphragms, utilities and utility supports, and sign supports, should typically not include the self-weight of the beams, as these are often calculated by the software. If this is not the case, or if there are other special circumstances, include the self-weight of the beam in the table and the reasoning shall be clearly noted.

Similarly, the weight of stay-in-place forms is typically neglected during design and shall be ignored in the load rating also, refer to Part II of this Bridge Manual for guidance.

7.4.2.7 Each element shall have the results of the analysis summarized in Rating Results Summary Reports produced by BrR. Elements shall be numbered to be consistent with the plans and inspection reports. In the event of a conflict regarding element numbers, the plans shall be followed. The first report shall determine the lowest rating value (analyzed by generating values at 1/10th points and at user defined points of interest) and the other reports, if necessary, shall determine the lowest rating value at each point of interest (generated by selecting the user defined points of interest button under the member alternatives description, engine tab, properties button).

7.4.2.8 All BrR files shall include a defined Bridge Alternative. The Bridge Alternative allows for Permit Route Analyses to be performed directly from BrR Bridge Explorer.

7.4.2.9 If the submitted BrR file contains two (2) or more entries under “SUPERSTRUCTURE DEFINITIONS”, then a corresponding entry is required under “SUPERSTRUCTURES” (BRIDGE ALTERNATIVES/SUPERSTRUCTURES). A further entry the next level down in “SUPERSTRUCTURES ALTERNATIVES” (BRIDGE ALTERNATIVES / SUPERSTRUCTURES / SUPERSTRUCTURE ALTERNATIVES) is also required, and the dropdown box should point back to the related entry under “SUPERSTRUCTURE DEFINITIONS”.

In this manner, each entry under the “SUPERSTRUCTURE DEFINITIONS” will be assigned an (E)(C), Existing and Current status.

7.4.2.10A All BrR files shall include the HL-93 design live load and all Rating Vehicles used in the rating analysis.

7.4.2.10B All BrR files shall include all Rating Vehicles used in the rating analysis.

7.4.2.11 The BrR output files shall include the following:

- BrR produced sketches of the bridge framing plan, bridge cross sections, and member elevations and cross sections for each span of steel stringer structures;
- BrR produced sketches of the bridge framing plan, bridge cross section, member elevations and cross sections, and strand locations at midspan and support locations for each span of prestressed concrete structures;
- BrR produced sketches of the bridge framing plan, bridge cross section, and member elevations and cross sections with the reinforcement for each span of reinforced concrete slab, T- beam and I-beam structures;
- BrR produced sketches of the bridge framing plan, bridge cross section, truss elevation, and member elevations and cross sections for each span of truss structures;
- BrR produced Rating Results Summary Reports for all members and points of interest;

7.4.2.12 The same submission requirements shall apply when an alternate approved computer program is utilized. For example, if CSiBridge, MIDAS, etc. are used, sketches showing legible node and element numbers shall be included.

7.4.3 Check of Calculations Submission

All rating calculations shall be reviewed with a check of the methods, assumptions, load distributions and BrR, or other approved computer software input files, in addition to a check of the actual calculations. The Standard Statement of Concurrence with the calculations shall be included in the Rating Report with the P.E. Stamp, date and signature of the Independent Reviewer. The Independent Reviewer's name and P.E. Number shall be typewritten below the signature line. The standard statement of concurrence shall be as follows:

"I HEREBY STATE THAT I HAVE CHECKED THE METHODS, ASSUMPTIONS, LOAD DISTRIBUTION, COMPUTER INPUT FILE(S) AND ALL CALCULATIONS FOR THIS RATING REPORT FOR BRIDGE NO. A-12-345 (ABC). BY SIGNING BELOW, I CONFIRM THAT I AGREE WITH ALL METHODS, ASSUMPTIONS, LOAD DISTRIBUTIONS, COMPUTER INPUT FILE(S), AND CALCULATIONS CONTAINED IN THIS RATING REPORT."

The Independent Reviewer shall be a Professional Engineer registered in the Commonwealth of Massachusetts. The Independent Reviewer and the Rating Engineer shall not be the same person.

7.5 RATING REPORT

7.5.1 Preparation and Format

The entire Rating Report shall be prepared as an electronic file in PDF format. The PDF file pages shall be sized as 8½" x 11" sheets. The font shall be Times New Romans with a minimum size 11. The PDF file shall also have a front and back cover that shall be color coded as follows: RED, if the rating for any posting vehicle is 6 tons or less; YELLOW, if the rating for any posting vehicle is more than 6 tons but less than statutory; and GREEN if the rating for any posting vehicle is statutory or greater. All pages that require a P.E. stamp shall be scanned after the stamp is affixed, signed and dated or generated electronically with an authentication method that links the stamp to the associated Registered Engineer.

The entire PDF file of the Rating Report shall be bookmarked so that the reader can navigate to each individual section directly without having to scroll through the entire file. The Appendices containing calculations or computer output shall be further bookmarked to match the index of the calculations or by each computer output (e.g., Beam #1, etc.) so that the reader can navigate to a particular calculation or output of interest.

The Facility Carried / Feature Intersected and Memorial Name/Local Name listed on the Rating Report cover shall be as described in Paragraph 7.3.1.1.

7.5.2 Report Organization

The Rating Report PDF file shall consist of the following sections, organized in the following order:

1. REPORT COVER

- 1.1 P.E. Stamp with date and signature of the Rating Engineer shall be placed here.
- 1.2 Color coded background and formatted as discussed in Subsection 7.5.1 and as shown in Figure 7.5.2-1

2. INDEX

- 2.1 Index of sections outlined with page numbers.

3. SUMMARY OF BRIDGE RATING

- 3.1 Tabular listing of the controlling rating values from the Breakdown of Bridge Rating (see below). Item 64 shall not be lower than Item 66.
- 3.2 P.E. Stamp with date and signature of the Rating Engineer shall be placed here.
- 3.3 Formatted as shown in Figure 7.5.2-2A or 7.5.2-4B for all structures.

4. BREAKDOWN OF BRIDGE RATING

- 4.1 Tabular listing of all bridge elements that must be rated to determine the rating of the bridge and at all points of interest as described in Subsection 7.2.2. All ratings below statutory shall have the text highlighted with the appropriate color. The controlling rating cell shall be shaded solid with the appropriate color, Green (red=0, green=176, blue=80), Yellow (red=255, green=255, blue=0), Red (red=255, green=0, blue=0), and the text shall be bold. For legibility, the font color for red and green shading and highlighting shall be white. All cells in the Breakdown shall be filled in. Elements that do not require a rating shall be noted with a dash.
- 4.2 When alternative ratings using actual lane locations are provided, then these ratings shall be performed at the same points of interest and placed underneath the original ratings at each row. The cells are to be shaded and formatted as described above. These rating values shall be the controlling ratings for these members.
- 4.3 Formatted as shown in Figures 7.5.2-3A(1) through 7.5.2-3A(3), and 7.5.2-6A, or 7.5.2-5B(1) through 7.5.2-5B(3), and 7.5.2-6B.
- 4.4 Formatted as shown in Figure 7.5.2-7 when alternative rating factors using actual lane locations are provided.

5. LOCATION MAP

- 5.1 The location map shall be a street map in color and provide sufficient landmarks and adjacent highway information to allow the user to find the bridge in the field without additional information. Satellite or aerial photographs and topography maps are not acceptable substitutes.

6. DESCRIPTION OF BRIDGE

- 6.1 Formatted as shown in Figure 7.5.2-8. It shall be noted that the Modifications to Superstructure and Substructure sections are reserved for structural changes. Revisions to railings, wearing surface, etc. shall be covered elsewhere in the Description of Bridge.

7. RATING ANALYSIS ASSUMPTIONS AND CRITERIA

- 7.1 Description of all methods, assumptions, allowable stresses, and strengths used to determine the rating of the structure, including computer programs, with version or release numbers utilized.
- 7.2 Statement of the applicability of the substructure and/or deck to the rating.

8. EVALUATION OF RATING AND RECOMMENDATIONS

- 8.1 Summary of controlling elements of the structure and recommendations to either improve or maintain the condition of the structure as described in Subsection 7.2.11.
- 8.2 Comparison of rating to previous rating as described in Paragraph 7.2.11.1 and as shown in Figure 7.5.2-9.

9. AVAILABLE PLANS, INSPECTION REPORTS, AND REFERENCES

- 9.1 Listing of all plans, latest inspection report(s) used and their sources that were made available to the Rating Engineer for the purpose of preparing the Rating Report.
- 9.2 Identify unique references that were used to develop the rating that an independent reviewer may not be aware of, i.e. studies or reports, and textbooks included in Appendix F. For a Design Rating, identify the specific version and date of the MassDOT Bridge Manual that was used for the design and rating.

10. LOADINGS USED FOR BRIDGE RATING

- 10.1 Standard diagrams of vehicles used in the rating showing axle weights and spacing as shown in Figures 7.5.2-10A, 7.5.2-10B, 7.5.2-11, 7.5.2-12, and/or 7.5.2-13A as applicable.

11. APPENDIX A - INSPECTION REPORTS

- 11.1 Inspection Reports including structure inventory and appraisal (SI&A), structures inspection field report and field notes. The first page shall be the latest SI&A sheet. Inspection Reports must be the latest available Routine, Routine & Special Member and Underwater at the time the Rating Report is submitted and shall include color reproductions of all inspection report photos. The National Bridge Element Inspection (PONTIS) pages shall not be included.

12. APPENDIX B - PHOTOS

- 12.1 An abundant number of color photographs of the structure, each no smaller than 3” by 5” on the page, including both elevation views, views of both approaches, framing views (if it varies, one of each type) and sufficient critical member photos shall be provided to adequately display the current condition of the structure. An index of all photos shall precede the photos. Photos of deficiencies where findings are different from those noted in the Inspection Reports shall be included.

13. APPENDIX C - COMPUTATIONS

- 13.1 The Standard Statement of Concurrence of the Independent Reviewer (see Subsection 7.4.3) on a separate page.
- 13.2 Tabular summary of all non-composite dead loads, composite dead loads, and live load distribution factors, etc., per beam.
- 13.3 Plan, framing plan, and bridge cross sections, as well as unique details and elements, as appropriate to identify all members that have been rated and included in Breakdown of Rating tables.
- 13.4 All hand calculations and computer aided calculations prepared as specified in Subsection 7.4.1 along with an index.

14. APPENDIX D - COMPUTER INPUT AND OUTPUT

- 14.1 Copies of all input and output summary pages, including software generated sketches of the bridge/framing plan, bridge cross section (including sidewalks, railings, barriers, and/or medians), member elevations and cross sections from computer programs used in rating the structure, and the controlling ratings that are included in the Breakdown of Bridge Rating, controlling values highlighted.

- 14.2 A summary page of all rating factors and rating values for each structure's particular elements shall be created and placed in front of each output of each particular element.

15. APPENDIX F - MISCELLANEOUS

- 15.1 Copies of material testing results and other miscellaneous reports/data that were used in the preparation of the Rating Report. Copies of unique reference or textbook pages that were used by the Rating Engineer in addition to AASHTO, including but not limited to those from old textbooks, codes, manuals, catalog cuts (i.e. custom rails, light standards, etc.), and design tables from manufacturers (i.e. Acrow panels, custom beam shapes, etc.).

16. CHECKLIST (separate from Report)

- 16.1 The Bridge Load Rating Report Checklist shall be submitted in a separate PDF file consisting of 8½"x11" pages.

7.5.3 Available Plans

7.5.3.1 Copies of all plans and shop drawings that were made available to the Rating Engineer and used in the preparation of the Rating Report shall be included in this folder. If the plans or shop drawings were provided in file formats other than PDF, the Rating Engineer shall convert them to PDF format prior to inclusion in this folder. Plans shall be combined into a single PDF file, per Construction Contract.

7.5.3.2 Organization. Each set of plans and shop drawings shall be placed in a separate folder. The name of the folder shall be the date the plans were advertised for construction, or if this is not available, then the latest date provided on the plans. These individual folders shall be placed in the main BRIDGE PLANS folder.

BRIDGE RATING

Prepared For

**MASSACHUSETTS DEPARTMENT OF TRANSPORTATION
HIGHWAY DIVISION**

DANA-PRESCOTT

MAIN STREET

OVER

SWIFT RIVER

BRIDGE NO. D-02-033=P-15-015(BG1)

STRUCTURE NO. D02033-BG1-DOT-NBI

SHODDY MILL BRIDGE

DATE OF INSPECTION

DATE OF RATING

PREPARED BY

P.E. Stamp with Signature and Date

Consultant Logo
Consultant Name
Consultant Address

Figure 7.5.2-1: Report Cover/Title Sheet

SUMMARY OF BRIDGE RATING

TOWN/CITY: DANA-PRESCOTT

BRIDGE NO.: D-02-033=P-15-015

CARRIES: MAIN STREET

OVER: SWIFT RIVER

STRUCTURE NO.: D02033-BG1-DOT-NBI

BIN NO.: BG1

RATINGS (TONS)

LRFR RATINGS FOR RATING VEHICLES LOAD RATINGS IN ENGLISH TONS		
VEHICLE TYPE	INVENTORY	OPERATING
H20	48.6	63.2
TYPE 3	48.8	63.4
TYPE 3S2	54.0	70.2
SU4	29.1	45.2
SU5	33.3	49.4
SU6	35.5	51.6
SU7	41.7	58.8
EV2	-	35.0
EV3	-	46.0

HL-93 LOAD AND RESISTANCE FACTOR RATING FACTORS PROVIDED IN COMPLIANCE WITH THE FHWA NBIS CODING GUIDE	
INVENTORY	OPERATING
ITEM 66	ITEM 64
1.2	2.3



A posting recommendation has been made based on the results of this Rating Report. This recommendation is contained in the "Memorandum to the NBIS File" for this bridge, dated _____.

Rating Engineer P.E. Stamp

State Bridge Engineer

Date

Figure 7.5.2-2A: Summary of Bridge Rating (LRFR)

BREAKDOWN OF BRIDGE RATING

TOWN/CITY: DANA-PRESCOTT

BRIDGE NO.: D-02-033=P-15-015

CARRIES: MAIN STREET

OVER: SWIFT RIVER

STRUCTURE NO.: D02033-BG1-DOT-NBI

BIN NO.: BG1

BRIDGE ELEMENT ¹		INVENTORY RATING BY LRFR METHOD (ENGLISH TONS)			OPERATING RATING BY LRFR METHOD (ENGLISH TONS)		
		H20	Type 3	Type 3S2	H20	Type 3	Type 3S2
EXTERIOR SIDEWALK BEAMS, NO.1 & 5	BOTTOM PLATE TRANSITION AT X = 20'-0 1/4"	105.5	115.9	152.0	137.1	150.7	197.7
	FLEXURAL STRENGTH AT 0.5L	77.4	87.2	119.2	100.6	113.4	155.0
1ST INTERIOR ROADWAY BEAMS, NO.2 & 4	BOTTOM PLATE TRANSITION AT X = 15'-4 1/4"	63.7	73.4	112.9	82.9	95.4	146.8
	FLEXURAL STRENGTH AT 0.5L	48.3	58.0	91.0	62.7	75.4	118.4
INTERIOR BEAM, NO.3	BOTTOM PLATE TRANSITION AT X = 10'-7 5/8"	105.2	114.2	143.8	136.4	148.1	186.4
	FLEXURAL STRENGTH AT 0.5L	71.9	79.9	104.4	93.3	103.6	135.3

Shaded cells are controlling ratings

Highlighted values are below statutory

Note:

For this report, beams and bays are numbered from the south consistent with the latest Routine Inspection Report

Figure 7.5.2-3A(1): Breakdown of Bridge Rating – Steel Beams (LRFR)

BREAKDOWN OF BRIDGE RATING

TOWN/CITY: DANA-PRESCOTT

BRIDGE NO.: D-02-033=P-15-015

CARRIES: MAIN STREET

OVER: SWIFT RIVER

STRUCTURE NO.: D02033-BG1-DOT-NBI

BIN NO.: BG1

BRIDGE ELEMENT ¹		INVENTORY RATING BY LRFR METHOD (ENGLISH TONS)				OPERATING RATING BY LRFR METHOD (ENGLISH TONS)					
		SU4	SU5	SU6	SU7	SU4	SU5	SU6	SU7	EV2	EV3
EXTERIOR SIDEWALK BEAMS, NO.1 & 5	BOTTOM PLATE TRANSITION AT X = 20'-0 1/4"	113.5	117.1	120.4	126.7	147.6	152.3	156.6	164.7	176.4	178.2
	FLEXURAL STRENGTH AT 0.5L	83.5	87.1	87.6	89.6	108.5	113.3	113.8	116.4	136.6	133.4
1ST INTERIOR ROADWAY BEAMS, NO.2 & 4	BOTTOM PLATE TRANSITION AT X = 15'-4 1/4"	71.1	74.5	78.0	84.5	92.4	96.9	101.4	109.8	147.2	149.4
	FLEXURAL STRENGTH AT 0.5L	54.1	57.9	58.3	60.5	70.3	75.2	75.8	78.6	121.5	117.0
INTERIOR BEAM, NO.3	BOTTOM PLATE TRANSITION AT X = 10'-7 5/8"	112.2	115.3	118.6	123.8	145.4	149.4	153.8	160.5	186.9	188.5
	FLEXURAL STRENGTH AT 0.5L	76.9	79.8	80.2	81.8	99.7	103.5	103.9	106.0	135.7	132.9

Shaded cells are controlling ratings

Highlighted values are below statutory

Note:

For this report, beams and bays are numbered from the south consistent with the latest Routine Inspection Report

Figure 7.5.2-3A(2): Breakdown of Bridge Rating – Steel Beams (LRFR)

BREAKDOWN OF BRIDGE RATING

TOWN/CITY: DANA-PRESCOTT

BRIDGE NO.: D-02-033=P-15-015

CARRIES: MAIN STREET

OVER: SWIFT RIVER

STRUCTURE NO.: D02033-BG1-DOT-NBI

BIN NO.: BG1

BRIDGE ELEMENT ¹		INVENTORY LRFR RATING FACTORS		OPERATING LRFR RATING FACTORS	
		HL-93 TRUCK & LANE LOAD	HL-93 TANDEM & LANE LOAD	HL-93 TRUCK & LANE LOAD	HL-93 TANDEM & LANE LOAD
EXTERIOR SIDEWALK BEAMS, NO.1 & 5	BOTTOM PLATE TRANSITION AT X = 20'-0 1/4"	2.6	3.1	3.4	4.0
	FLEXURAL STRENGTH AT 0.5L	2.0	2.2	2.6	3.3
1ST INTERIOR ROADWAY BEAMS, NO.2 & 4	BOTTOM PLATE TRANSITION AT X = 15'-4 1/4"	1.8	2.0	2.3	2.6
	FLEXURAL STRENGTH AT 0.5L	1.4	1.5	1.8	1.9
INTERIOR BEAM, NO.3	BOTTOM PLATE TRANSITION AT X = 10'-7 5/8"	2.5	3.0	3.3	3.9
	FLEXURAL STRENGTH AT 0.5L	1.8	2.0	2.3	2.6

Shaded cells are controlling ratings

Highlighted values are below statutory

Note:

For this report, beams and bays are numbered from the south consistent with the latest Routine Inspection Report

Figure 7.5.2-3A(3): Breakdown of Bridge Rating – Steel Beams (LRFR)

SUMMARY OF BRIDGE RATING

TOWN/CITY: DANA-PRESCOTT

BRIDGE NO.: D-02-033=P-15-015

CARRIES: MAIN STREET

OVER: SWIFT RIVER

STRUCTURE NO.: D02033-BG1-DOT-NBI

BIN NO.: BG1

RATINGS (TONS)

ALLOWABLE STRESS RATINGS FOR RATING VEHICLES LOAD RATINGS IN ENGLISH TONS		
VEHICLE TYPE	INVENTORY	OPERATING
H20	32.4	72.2
TYPE 3	32.5	73.3
TYPE 3S2	36.0	81.4
HS20	32.8	73.8
SU4	29.1	45.2
SU5	33.3	49.4
SU6	35.5	51.6
SU7	41.7	58.8
EV2	-	35.0
EV3	-	46.0

MS18 LOAD FACTOR RATING IN METRIC TONS PROVIDED IN COMPLIANCE WITH THE FHWA NBIS CODING GUIDE			
INVENTORY		OPERATING	
ITEM 66	MS Equivalent	ITEM 64	MS Equivalent
46.5	MS25.8	78.1	MS43.4



A posting recommendation has been made based on the results of this Rating Report. This recommendation is contained in the "Memorandum to the NBIS File" for this bridge, dated _____.

Rating Engineer P.E. Stamp

State Bridge Engineer

Date

Figure 7.5.2-4B: Summary of Bridge Rating (ASR/LFR)

BREAKDOWN OF BRIDGE RATING

TOWN/CITY: DANA-PRESCOTT

BRIDGE NO.: D-02-033=P-15-015

CARRIES: MAIN STREET

OVER: SWIFT RIVER

STRUCTURE NO.: D02033-BG1-DOT-NBI

BIN NO.: BG1

BRIDGE ELEMENT ¹		INVENTORY RATING BY ALLOWABLE STRESS METHOD (ENGLISH TONS)				OPERATING RATING BY ALLOWABLE STRESS METHOD (ENGLISH TONS)			
		H20	Type 3	Type 3S2	HS20	H20	Type 3	Type 3S2	HS20
EXTERIOR SIDEWALK BEAMS, NO.1 & 5	BOTTOM PLATE TRANSITION AT X = 20'-0 1/4"	49.3	53.2	63.7	55.2	93.8	101.2	121.2	105.0
	FLEXURAL STRENGTH AT 0.5L	36.7	39.6	47.4	41.1	69.8	75.3	90.2	78.2
1ST INTERIOR ROADWAY BEAMS, NO.2 & 4	BOTTOM PLATE TRANSITION AT X = 20'-0 1/4"	31.3	33.5	39.5	34.5	61.9	66.2	78.1	68.1
	FLEXURAL STRENGTH AT 0.5L	23.3	25.1	30.1	26.1	62.4	67.2	80.6	69.8
	SHEAR AT WEST SUPPORT DUE TO DETERIORATION	20.0	22.5	31.0	23.8	32.2	36.3	49.7	38.2
	WEB YIELDING AT WEST SUPPORT DUE TO DETERIORATION	2.6	3.0	4.0	3.2	8.6	9.5	13.0	10.1
INTERIOR BEAM, NO.3	BOTTOM PLATE TRANSITION AT X = 20'-0 1/4"	31.7	33.9	40.0	34.8	62.3	66.6	78.6	68.5
	FLEXURAL STRENGTH AT 0.5L	24.9	26.9	32.2	27.9	62.7	67.6	81.0	70.2

Shaded cells are controlling ratings

Highlighted values are below statutory

Note:

For this report, beams and bays are numbered from the south consistent with the latest Routine Inspection Report

Figure 7.5.2-5B(1): Breakdown of Bridge Rating – Steel Beams (ASR/LFR)

BREAKDOWN OF BRIDGE RATING

TOWN/CITY: DANA-PRESCOTT

BRIDGE NO.: D-02-033=P-15-015

CARRIES: MAIN STREET

OVER: SWIFT RIVER

STRUCTURE NO.: D02033-BG1-DOT-NBI

BIN NO.: BG1

BRIDGE ELEMENT ¹		INVENTORY RATING BY ALLOWABLE STRESS METHOD (ENGLISH TONS)				OPERATING RATING BY ALLOWABLE STRESS METHOD (ENGLISH TONS)					
		SU4	SU5	SU6	SU7	SU4	SU5	SU6	SU7	EV2	EV3
EXTERIOR SIDEWALK BEAM, NO.1 & 5	BOTTOM PLATE TRANSITION AT X = 20'-0 1/4"	52.1	53.6	53.7	54.4	99.0	101.7	102.0	103.5	102.1	100.6
	FLEXURAL STRENGTH AT 0.5L	38.5	39.6	39.7	40.2	73.2	75.2	75.4	76.5	75.5	74.4
1ST INTERIOR ROADWAY BEAM, NO.2 & 4	BOTTOM PLATE TRANSITION AT X = 20'-0 1/4"	33.0	33.7	33.9	34.8	65.2	66.7	67.1	68.9	65.1	65.5
	FLEXURAL STRENGTH AT 0.5L	24.4	25.1	25.2	25.5	65.4	67.2	67.4	68.3	67.4	66.4
	SHEAR AT WEST SUPPORT DUE TO DETERIORATION	27.0	28.6	29.4	26.8	89.3	90.6	96.2	83.5	75.2	95.9
	WEB YIELDING AT WEST SUPPORT DUE TO DETERIORATION	3.5	3.7	3.8	3.5	11.6	11.8	12.5	10.9	9.8	12.5
INTERIOR BEAM, NO.3	BOTTOM PLATE TRANSITION AT X = 20'-0 1/4"	33.4	34.1	34.3	35.2	65.6	67.1	67.5	69.2	65.4	65.9
	FLEXURAL STRENGTH AT 0.5L	26.3	27.0	27.1	27.5	65.8	67.5	67.8	68.7	67.8	66.8

Shaded cells are controlling ratings

Highlighted values are below statutory

Note:

For this report, beams and bays are numbered from the south consistent with the latest Routine Inspection Report

Figure 7.5.2-5B(2): Breakdown of Bridge Rating – Steel Beams (ASR/LFR)

BREAKDOWN OF BRIDGE RATING

TOWN/CITY: DANA-PRESCOTT

BRIDGE NO.: D-02-033=P-15-015

CARRIES: MAIN STREET

OVER: SWIFT RIVER

STRUCTURE NO.: D02033-BG1-DOT-NBI

BIN NO.: BG1

BRIDGE ELEMENT ¹		INVENTORY RATING BY LOAD FACTOR METHOD (METRIC TONS)		OPERATING RATING BY LOAD FACTOR METHOD (METRIC TONS)	
		MS18	MS (EQUIV)	MS18	MS (EQUIV)
EXTERIOR SIDEWALK BEAMS, NO.1 & 5	BOTTOM PLATE TRANSITION AT X = 20'-0 1/4"	59.6	MS33.1	99.5	MS55.3
	FLEXURAL STRENGTH AT 0.5L	44.1	MS24.5	73.6	MS40.9
1ST INTERIOR ROADWAY BEAMS, NO.2 & 4	BOTTOM PLATE TRANSITION AT X = 20'-0 1/4"	38.5	MS21.4	64.2	MS35.7
	FLEXURAL STRENGTH AT 0.5L	39.4	MS21.9	65.9	MS36.6
	SHEAR AT WEST SUPPORT DUE TO DETERIORATION	22.3	MS12.4	37.3	MS20.7
	WEB YIELDING AT WEST SUPPORT DUE TO DETERIORATION	2.9	MS1.6	4.8	MS2.7
INTERIOR BEAM, NO.3	BOTTOM PLATE TRANSITION AT X = 20'-0 1/4"	38.7	MS21.5	64.6	MS35.9
	FLEXURAL STRENGTH AT 0.5L	39.6	MS22.0	66.2	MS36.8

Shaded cells are controlling ratings

Highlighted values are below statutory

Note:

For this report, beams and bays are numbered from the south consistent with the latest Routine Inspection Report

Figure 7.5.2-5B(3): Breakdown of Bridge Rating – Steel Beams (ASR/LFR)

BREAKDOWN OF BRIDGE RATING

TOWN/CITY: DANA-PRESCOTT

BRIDGE NO.: D-02-033=P-15-015

CARRIES: MAIN STREET

OVER: SWIFT RIVER

STRUCTURE NO.: D02033-BG1-DOT-NBI

BIN NO.: BG1

BRIDGE ELEMENT ¹		INVENTORY RATING BY LRFR METHOD (ENGLISH TONS)			OPERATING RATING BY LRFR METHOD (ENGLISH TONS)		
		H20	Type 3	Type 3S2	H20	Type 3	Type 3S2
EXTERIOR SIDEWALK BEAMS, NO.1 & 5	CONCRETE SHEAR AT H/2	40.8	47.2	73.2	52.3	61.1	94.9
	CONCRETE TENSION @ SERVICE AT 0.50L	25.3	31.7	48.4	-	-	-
	CONCRETE COMPRESSION @ SERVICE AT 0.50L	30.2	37.8	57.8	-	-	-
	FLEXURAL STRENGTH AT 0.50L	35.0	43.9	67.1	45.4	56.9	87.0
1ST INTERIOR ROADWAY BEAMS, NO.2 & 4	CONCRETE SHEAR AT H/2	32.6	37.7	58.5	42.3	48.8	75.9
	CONCRETE TENSION @ SERVICE AT 0.50L	31.2	39.1	59.8	-	-	-
	CONCRETE COMPRESSION @ SERVICE AT 0.50L	33.4	44.5	68.1	-	-	-
	FLEXURAL STRENGTH AT 0.50L	35.5	44.5	68.1	46.0	57.7	89.1
INTERIOR BEAMS, NO.3 - NO.6	CONCRETE SHEAR AT H/2	32.7	37.7	58.6	42.3	48.9	75.9
	CONCRETE TENSION @ SERVICE AT 0.50L	18.9	23.7	36.2	-	-	-
	CONCRETE COMPRESSION @ SERVICE AT 0.50L	21.2	26.6	40.6	-	-	-
	FLEXURAL STRENGTH AT 0.50L	23.5	29.4	45.0	30.4	38.2	58.4

Shaded cells are controlling ratings

Highlighted values are below statutory

Note:

For this report, beams and bays are numbered from the south consistent with the latest Routine Inspection Report

Figure 7.5.2-6A: Breakdown of Bridge Rating – Prestressed Beams (LRFR)

BREAKDOWN OF BRIDGE RATING

TOWN/CITY: DANA-PRESCOTT

BRIDGE NO.: D-02-033=P-15-015

CARRIES: MAIN STREET

OVER: SWIFT RIVER

STRUCTURE NO.: D02033-BG1-DOT-NBI

BIN NO.: BG1

BRIDGE ELEMENT ¹		INVENTORY RATING BY LOAD FACTOR METHOD (ENGLISH TONS)				OPERATING RATING BY LOAD FACTOR METHOD (ENGLISH TONS)			
		H20	Type 3	Type 3S2	HS20	H20	Type 3	Type 3S2	HS20
EXTERIOR SIDEWALK BEAMS, NO.1 & 5	CONCRETE SHEAR AT H/2	53.1	61.2	94.5	65.3	88.7	102.2	157.8	109.0
	CONCRETE TENSION AT 0.50L	26.9	33.7	51.6	38.4	-	-	-	-
	CONCRETE COMPRESSION AT 0.50L	31.6	39.6	60.6	45.1	-	-	-	-
	FLEXURAL STRENGTH AT 0.50L	36.3	45.5	69.6	51.8	60.6	76.0	116.2	86.5
1ST INTERIOR ROADWAY BEAMS, NO.2 & 4	CONCRETE SHEAR AT H/2	58.5	67.4	104.0	71.8	97.6	112.5	173.6	119.9
	CONCRETE TENSION AT 0.50L	43.7	54.8	83.8	62.4	-	-	-	-
	CONCRETE COMPRESSION AT 0.50L	43.7	54.8	83.8	62.4	-	-	-	-
	FLEXURAL STRENGTH AT 0.50L	49.2	61.7	94.3	70.2	82.2	103.0	157.5	117.3
INTERIOR BEAMS, NO.3 - NO.6	CONCRETE SHEAR AT H/2	52.2	60.1	92.8	64.1	87.1	100.4	154.9	107.0
	CONCRETE TENSION AT 0.50L	26.7	33.4	51.1	38.1	-	-	-	-
	CONCRETE COMPRESSION AT 0.50L	29.7	37.2	56.9	42.4	-	-	-	-
	FLEXURAL STRENGTH AT 0.50L	32.7	41.0	62.7	46.7	54.6	68.5	104.8	78.0

Shaded cells are controlling ratings
Highlighted values are below statutory

Note:

For this report, beams and bays are numbered from the south consistent with the latest Routine Inspection Report

Figure 7.5.2-6B: Breakdown of Bridge Rating – Prestressed Beams (LFR)

BREAKDOWN OF BRIDGE RATING

TOWN/CITY: DANA-PRESCOTT

BRIDGE NO.: D-02-033=P-15-015

CARRIES: MAIN STREET

OVER: SWIFT RIVER

STRUCTURE NO.: D02033-BG1-DOT-NBI

BIN NO.: BG1

BRIDGE ELEMENT ¹		INVENTORY RATING BY ALLOWABLE STRESS METHOD (ENGLISH TONS)				OPERATING RATING BY ALLOWABLE STRESS METHOD (ENGLISH TONS)			
		H20	Type 3	Type 3S2	HS20	H20	Type 3	Type 3S2	HS20
EXTERIOR SIDEWALK BEAMS, NO.1 & 6	TOP & BOTTOM PLATE TRANSITION AT X = 23'-0"	20.2	21.7	26.0	22.4	43.4	46.8	56.0	48.3
	TOP & BOTTOM PLATE TRANSITION AT X = 23'-0"2	29.7	32.0	38.3	33.0	63.9	68.8	82.4	71.0
	FLEXURAL STRENGTH AT 0.5L	19.8	21.5	26.2	22.4	42.8	46.4	56.7	48.4
	FLEXURAL STRENGTH AT 0.5L2	29.1	31.6	38.5	32.9	62.9	68.2	83.3	71.2
1ST INTERIOR ROADWAY BEAMS, NO.2 & 5	TOP & BOTTOM PLATE TRANSITION AT X = 23'-0"	23.4	25.2	30.2	26.0	44.2	47.6	57.0	49.2
	TOP & BOTTOM PLATE TRANSITION AT X = 23'-0"2	36.0	38.8	46.4	40.0	68.1	73.3	87.8	75.6
	FLEXURAL STRENGTH AT 0.5L	26.3	31.5	49.6	34.9	42.6	51.2	80.4	56.6
	FLEXURAL STRENGTH AT 0.5L2	40.4	48.5	76.3	53.7	65.5	78.7	123.7	87.0
INTERIOR BEAMS, NO.3 & 4	TOP & BOTTOM PLATE TRANSITION AT X = 23'-0"	32.5	35.0	41.8	36.1	66.4	71.5	85.5	73.7
	FLEXURAL STRENGTH AT 0.5L	31.3	34.0	41.4	35.5	64.7	70.2	85.5	73.2

Shaded cells are controlling ratings
Highlighted values are below statutory

Notes:

1. For this report, beams and bays are numbered from the south consistent with the latest Routine Inspection Report.
2. Live Load application based upon AASHTO MBE 6B.6.2.2; live load distributed to exterior or 1st interior using lever rule and actual lane location.

Figure 7.5.2-7: Breakdown of Bridge Rating – Alternative Rating Using Actual Lane Location

DESCRIPTION OF BRIDGE

<u>DANA-PRESCOTT</u>	<u>MAIN STREET / SWIFT RIVER</u>	<u>BRIDGE NO. D-02-033=P-15-015</u>
Date of Construction:	1952 (Original), 1974 (widening)	
Original Design Loading:	H15-44	
Posted Limit:	H20: 18 Tons, Type 3: 21 Tons, Type 3S2: 31 Tons	
Bridge Type:	2 simple spans of rolled steel beams with an 8" thick composite concrete deck	
Skew:	40°-16'-02"	
Spans:	Spans 1 & 2: 87'-5¼", center-to-center of bearing (per the plans)	
Width of Bridge Deck:	53'-0" out-to-out of deck slab (per the plans)	
Roadway Width:	40'-0" curb-to-curb (field verified 8/12/18)	
Roadway Surface:	3" bituminous concrete (field verified 8/12/18)	
Curbs:	Granite curb both sides with 7¼" average reveal (field verified 8/12/18)	
Sidewalk/Walkway/Median:	2 – 6'-6" sidewalks	
Bridge Railing:	Type H steel pedestrian rail and Type I protective screen along both sides of bridge	
Approach Railing:	W-beam highway guard at all four corners	
Superstructure:	Spans 1 & 2: 6 - 36WF245 and 2 – W36x260	
Modifications to Original Superstructure:	Safety curb removed and deck widened to add sidewalk and utility bay	
Utilities:	1–12" dia. cast iron water pipe, with 3" insulation, 1–10" dia. cast iron gas pipe in Bay 7	
Substructure:	2 cantilever reinforced concrete abutments, 1 reinforced concrete multi-column pier, reinforced concrete wingwalls at all four corners	
Modifications to Original Substructure:	Widened to accommodate superstructure	

Figure 7.5.2-8: Description of Bridge

COMPARISON OF RATINGS

TOWN/CITY: DANA-PRESCOTT

BRIDGE NO.: D-02-033=P-15-015

CARRIES: MAIN STREET

OVER: SWIFT RIVER

STRUCTURE NO.: D02033-BG1-DOT-NB1

BIN NO.: BG1

Year of Report	1988	2018
Rating Engineer	Firm A	Firm B
Inventory RF	0.90 (HS20)	1.21 (HS20)
Controlling Element	S26 - Span 3 (Shear)	S26 - Span 3 (Shear)
Rating Software	Hand Calculations	AASHTOWare
Analysis Criteria		
f_c (deck)	3 ksi	4 ksi
F_y (steel stringer)	36 ksi	36 ksi
Notable Discrepancies	<ol style="list-style-type: none"> 1. Steel deterioration at beam ends 2. Concrete deck based on MCEB date of construction 	<ol style="list-style-type: none"> 1. Rehabilitation project restored beam ends 2. Concrete strength based on review of MassDOT Standard Specifications for time of construction

Figure 7.5.2-9: Comparison of Ratings

LOADINGS USED FOR BRIDGE RATING

DANA-PRESCOTT

MAIN STREET / SWIFT RIVER

BRIDGE NO. D-02-033=P-15-015

H20 VEHICLE

TOTAL WEIGHT
 20 TONS

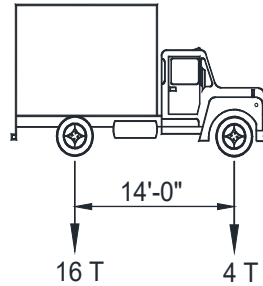

TYPE 3 VEHICLE

TOTAL WEIGHT
 25 TONS

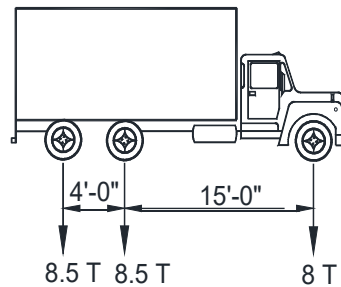

TYPE 3S2 VEHICLE

TOTAL WEIGHT
 36 TONS

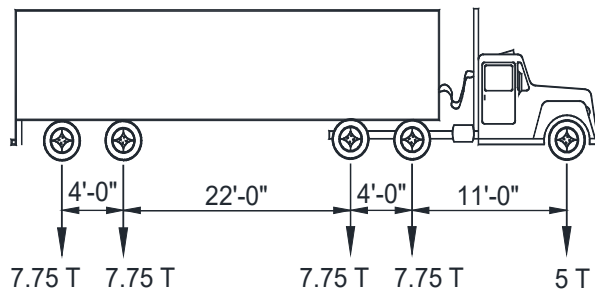

Figure 7.5.2-10A: Vehicle Diagrams (LRFR)

LOADINGS USED FOR BRIDGE RATING

DANA-PRESCOTT

MAIN STREET / SWIFT RIVER

BRIDGE NO. D-02-033=P-15-015

H20 VEHICLE

TOTAL WEIGHT
20 TONS

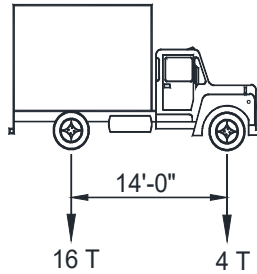

TYPE 3 VEHICLE

TOTAL WEIGHT
25 TONS

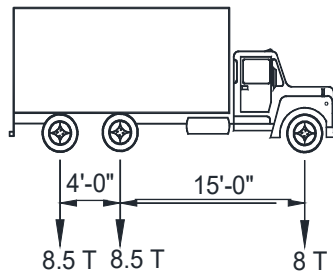

TYPE 3S2 VEHICLE

TOTAL WEIGHT
36 TONS

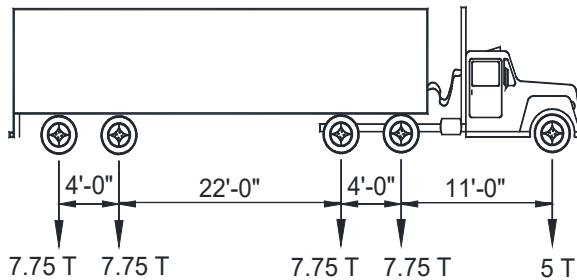

HS20 VEHICLE

TOTAL WEIGHT
36 TONS

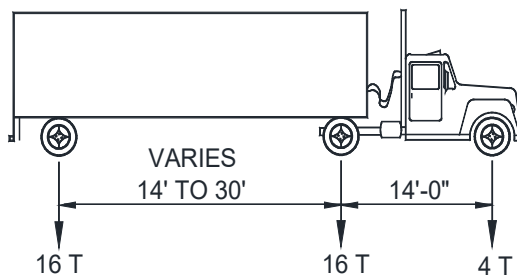

Figure 7.5.2-10B: Vehicle Diagrams (ASR/LFR)

LOADINGS USED FOR BRIDGE RATING

DANA-PRESCOTT

MAIN STREET / SWIFT RIVER

BRIDGE NO. D-02-033=P-15-015

SU4 TRUCK

TOTAL WEIGHT
27 TONS

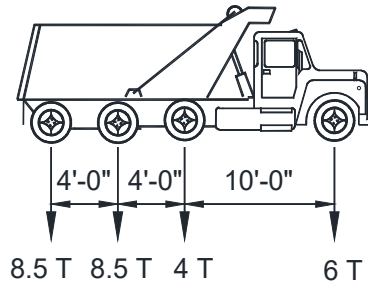

SU5 TRUCK

TOTAL WEIGHT
31 TONS

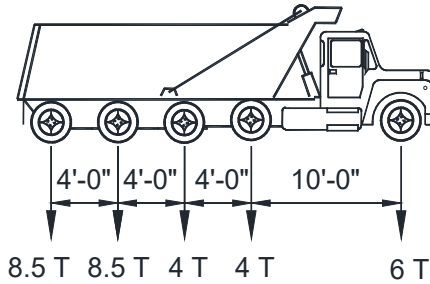

SU6 TRUCK

TOTAL WEIGHT
34.75 TONS

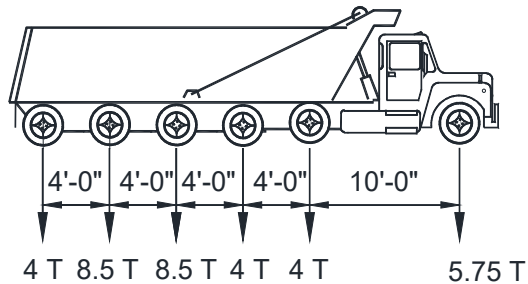

SU7 TRUCK

TOTAL WEIGHT
38.75 TONS

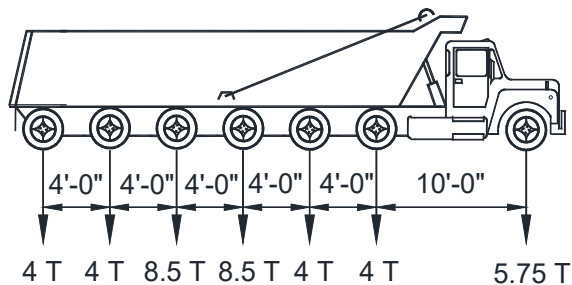

Figure 7.5.2-11: Vehicle Diagrams – Specialized Hauling Vehicles

LOADINGS USED FOR BRIDGE RATING

DANA-PRESCOTT

MAIN STREET / SWIFT RIVER

BRIDGE NO. D-02-033=P-15-015

EV2 VEHICLE

TOTAL WEIGHT
28.75 TONS

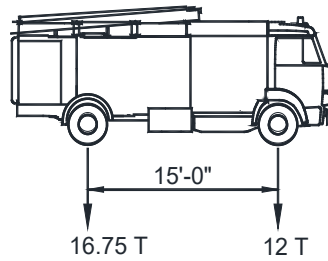

EV3 VEHICLE

TOTAL WEIGHT
43 TONS

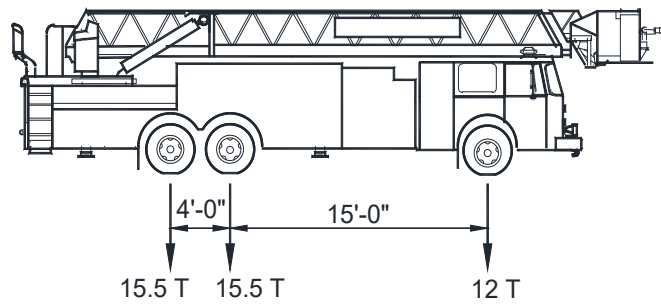

Figure 7.5.2-12: Vehicle Diagrams – Emergency Vehicles

LOADINGS USED FOR BRIDGE RATING

DANA-PRESCOTT

MAIN STREET / SWIFT RIVER

BRIDGE NO. D-02-033=P-15-015

HL-93 LOADING

Indicated Concentrations are Axle Loads in Kips

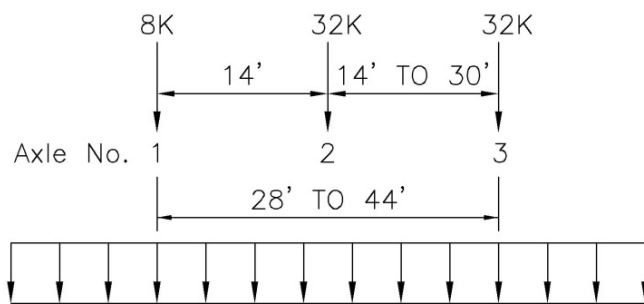

HL-93 Truck = 72 Kips (36 Tons)

HL-93 Lane Load = 0.64 klf

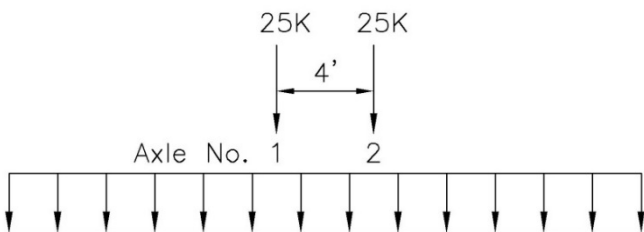

HL-93 Tandem = 50 Kips (25 tons)

HL-93 Lane Load = 0.64 klf

Additional Load Model for Negative Moment and Interior Reaction

(Reduce all Loads to 90%)

Design Lane Load = 0.64 klf

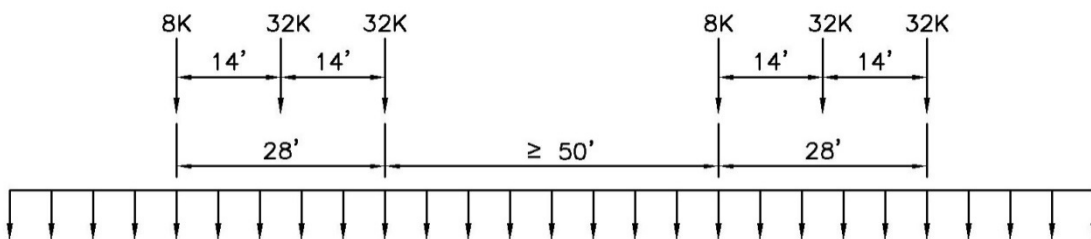

Figure 7.5.2-13A: Vehicle Diagrams – HL-93



BRIDGE LOAD RATING REPORT CHECKLIST

MassDOT Bridge Manual
Hundredth Anniversary Edition

CITY/TOWN:
DISTRICT:
FACILITY CARRIED:
FEATURES INTERSECTED:
BR. DEPT. NO.:
BIN:
STRUCTURE NO.:
MEMORIAL NAME/LOCAL NAME:

SUBMITTED BY:

Rating Engineer: The Rating Engineer shall be a Professional Engineer (PE) registered in the Commonwealth of Massachusetts in Responsible Charge of the work.

The **Rating Engineer** certifies that they have reviewed the Bridge Load Rating Report in accordance with this checklist and that all responses on this checklist are correct and accurately reflect the information presented in the submitted Rating Report.

SIGNATURE OF RATING ENGINEER
FIRM NAME:

DATE

CHECKLIST INSTRUCTIONS:

The purpose of this checklist is to help the Rating Engineer and Independent Reviewer ensure that MassDOT standards for Rating Reports have been followed and that all necessary information has been provided per the Bridge Manual (*Hundredth Anniversary Edition*)

As required by the Bridge Manual, Part I, Chapter 7, Section 7.1, Subsection 7.1.4 and Section 7.4, Subsection 7.4.3, the Rating Engineer and Independent Reviewer shall be Professional Engineers, registered in the Commonwealth of Massachusetts. The Independent Reviewer and the Rating Engineer shall not be the same person.

Where a question requires the Rating Engineer to select NO (N) for a particular check box (i.e. for Truss Bridges where the bridge is not a truss), no explanation is necessary. In all other instances, a NO (N) response requires a written explanation if the space is provided.

A NO (N) response for items so designated, indicates a FATAL OMISSION that will result in automatic rejection of the Rating Report. Please note, that MassDOT reserves the right to reject any Rating Report that does not meet the requirements of the Bridge Manual at our discretion, regardless of whether an item is noted as a FATAL OMISSION or not.

Written explanations that are too long for the space provided shall be noted with a letter or number designation and written on the Additional/Supplemental Information page.

1. REPORT COVER

Y **N**
 For any submission other than the FINAL rating report, is the front cover unstamped, and unsigned, but the written agreement of the Independent Reviewer (Statement of Concurrence) included, signed, and dated, but not stamped by a Professional Engineer per the Bridge Manual, Part I, Chapter 7, Section 7.4, Subsection 7.4.3? (A NO (N) response indicates a FATAL OMISSION.) For the FINAL rating report select YES (Y).

Explanation:

Y **N**
 Is the FINAL rating report front cover stamped, signed, and dated by a PE and formatted per the Bridge Manual, Part I, Chapter 7, Figure 7.5.2-1? (A NO (N) response indicates a FATAL OMISSION.)

Explanation:

Y **N**
 Is the rating report cover the correct color?

2. INDEX

Y **N**
 Are the indexes of each section outlined with the page numbers shown correctly in the rating report?

Y **N**
 Is the rating report .PDF bookmarked so that the reader can navigate to each individual section without having to scroll through the file? Are the appendices containing calculations, or computer input and output, further bookmarked to match the index, and by each computer output (i.e. Beam #1, Beam #2, etc.) so that the reader can navigate to a particular calculation or output of interest? (A NO (N) response indicates a FATAL OMISSION.)

Explanation:

3. SUMMARY OF BRIDGE RATING

Y **N**
 Are the rating values on the Summary of Bridge Rating correctly tabulated identifying the controlling rating values from the Breakdown of Bridge Rating? (A NO (N) response indicates a FATAL OMISSION.)

Y **N**
 Are Items 64 and 66 (FHWA NBIS Factors or Ratings) entered for the controlling roadway beam(s) in accordance with the Bridge Manual, Part I, Chapter 7, Section 7.2, Subsection 7.2.4, Paragraph 7.2.4.2A or 7.2.4.2B?

Y **N**
 Is the value provided for Item 64 greater than or equal to the value provided for Item 66 (FHWA NBIS Factors or Ratings)? (A NO (N) response indicates a FATAL OMISSION.)

Y **N**
 Is the format of the Summary of Bridge Rating in accordance with the Bridge Manual, Part I, Chapter 7, Figure 7.5.2-2A or 7.5.2-4B? (A NO (N) response indicates a FATAL OMISSION.)

Explanation:

Y **N**
 Are the specialized hauling vehicles, SU4 through SU7, and the FAST Act emergency vehicles, EV2 and EV3, as shown in Figures 7.5.2-11 and 7.5.2-12 included in the Summary in accordance with the Bridge Manual, Part I, Chapter 7, Figure 7.5.2-2A or 7.5.2-4B?

Explanation:

4. BREAKDOWN OF BRIDGE RATING

Y **N**
 Are only the controlling rating values shaded solid, with rating values below statutory highlighted, with the font in the appropriate colors, formatted per the Bridge Manual, Part I, Chapter 7, Section 7.5, Subsection 7.5.2, Bullet 4.1?

Y **N**
 Is the Breakdown of Bridge Rating formatted per the Bridge Manual, Part I, Chapter 7, Figure 7.5.2-3A(1), 7.5.2-3A(2), & 7.5.2-3A(3), or 7.5.2-5B(1), 7.5.2-5B(2) & 7.5.2-5B(3), or 7.5.2-6A, or 7.5.2-6B, or 7.5.2-7?

Explanation:

Y **N**
 Is HL-93 or MS18 shaded solid only for the controlling roadway beam(s), with rating values below statutory highlighted, with the font in the appropriate colors, formatted per the Bridge Manual, Part I, Chapter 7, Figure 7.5.2-3A(3) or 7.5.2-5B(3)? (A NO (N) response indicates a FATAL OMISSION.)

Stringer/Girder and Girder/Floorbeam/Stringer Bridges, including Precast Concrete Bridges

Y **N**
 Is the bridge a Stringer/Girder or Girder/Floorbeam/Stringer Bridge?

Explanation:

Y **N**
 Are the rating values in the Breakdown of Bridge Rating tabulated at the critical locations per the Bridge Manual, Part I, Chapter 7, Section 7.2, Subsection 7.2.2, Paragraph 7.2.2.1? For non-Stringer/Girder and non-Girder/Floorbeam/Stringer bridges select NO (N).

Explanation:

Truss Bridges

Y **N**
 Are the rating values in the Breakdown of Bridge Rating tabulated at all chords, diagonals, floorbeams, stringers, bracing, and gusset plates per the Bridge Manual, Part I, Chapter 7, Section 7.2, Subsection 7.2.2, Paragraph 7.2.2.3A or 7.2.2.3B? For non-truss bridges select NO (N)

Explanation:

Concrete and Masonry Arches

Y **N**
 Are the rating values in the Breakdown of Bridge Rating tabulated at the crown, springlines, and quarter points per the Bridge Manual, Part I, Chapter 7, Section 7.2, Subsection 7.2.2, Paragraph 7.2.2.6? For non-arch bridges select NO (N).

Explanation:

Other Bridge Types

Y **N**
 Are the rating values in the Breakdown of Bridge Rating calculated for all primary elements and at all critical locations? For non-Other Bridge Types select NO (N).

Explanation:

5. LOCATION MAP

Y **N**
 Does the location map provide sufficient landmarks and adjacent highway information to allow the user to find the bridge in the field without additional information?

Explanation:

Y **N**
 Is the location map a street map in color? (no satellite imagery or topographic maps)

Explanation:

6. DESCRIPTION OF BRIDGE

Y **N**
 Is the Description of Bridge formatted per the Bridge Manual, Part I, Chapter 7, Figure 7.5.2-8?
Explanation:

7. RATING ANALYSIS ASSUMPTIONS AND CRITERIA

Y **N**
 Are all methods, assumptions, allowable stresses, strengths, and computer programs, including version, used to determine the rating clearly stated?
Explanation:

Y **N**
 Have the condition of the bridge substructure and superstructure been reviewed and evaluated? Has a statement regarding the review of each been included? (A NO (N) response indicates a FATAL OMISSION.)
Explanation:

Y **N**
 Is any additional discussion included for any condition or situation that is extraordinary for this structure?
Explanation:

Decks

Y **N**
 Has the condition of the concrete deck been reviewed and evaluated per the Bridge Manual, Part I, Chapter 7, Section 7.2, Subsection 7.2.2, Paragraph 7.2.2.7? Has a statement regarding the review, and rating, or not rating, of the deck been included? For timber, metal grid, or alternative decks select NO (N).
Explanation:

Y **N**
 Has the timber deck been rated per the Bridge Manual, Part I, Chapter 7, Section 7.2, Subsection 7.2.2, Paragraph 7.2.2.7? For concrete, metal grid, or alternative decks select NO (N).
Explanation:

Y **N**
 Have the purlins of the metal grid deck been rated per the Bridge Manual, Part I, Chapter 7, Section 7.2, Subsection 7.2.2, Paragraph 7.2.2.7? For concrete, timber, or alternative decks select NO (N).
Explanation:

Y **N**
 Has the alternative deck been discussed, reviewed, and evaluated per the Bridge Manual, Part I, Chapter 7, Section 7.2, Subsection 7.2.2, Paragraph 7.2.2.7? Has a statement regarding the review, and rating, or not rating, of the deck been included? For concrete, timber, or metal grid decks select NO (N).
Explanation:

7. RATING ANALYSIS ASSUMPTIONS AND CRITERIA (continued)

Alternate Load Rating Using Actual Lane Location

Y **N**
 Are the live load distribution factors, if required, using the actual travel lanes calculated per the Bridge Manual, Part I, Chapter 7, Section 7.2, Subsection 7.2.4, Paragraph 7.2.4.5? If the alternate load rating is not required select NO (N).

Explanation:

Special Instructions for Load Ratings

Y **N**
 Have clarifications or deviations from the Chapter 7 guidelines been submitted to the State Bridge Engineer, and all correspondence including responses been included? If no clarifications or deviations, select NO (N).

Explanation:

Y **N**
 For pile bents or non-reinforced concrete substructures, have the pile bent piles and the pile cap, or other non-reinforced concrete substructure, been rated in accordance with the Bridge Manual, Part I, Chapter 7, Section 7.2, Subsection 7.2.5, Paragraph 7.2.5.4? If no pile bent or non-reinforced concrete substructure, select NO (N).

Explanation:

Y **N**
 Have bearing pedestals and/or beam seats that are cracked, spalled, and undermined been reviewed, evaluated, and their bearing strength confirmed?

Explanation:

Y **N**
 For structures with unknown structural details and no Construction Drawings, have detailed field measurements, non-destructive testing, and/or a material testing program been performed per the Bridge Manual, Part I, Chapter 7, Section 7.2, Subsection 7.2.5, Paragraph 7.2.5.5?

Explanation:

Prestressed Members including Adjacent Prestressed Beams

Y **N**
 Have the special instructions for Prestressed Members been followed per the Bridge Manual, Part I, Chapter 7, Section 7.2, Subsection 7.2.6? For non-precast member structures select NO (N).

Explanation:

Concrete and Masonry Arches

Y **N**
 Have the special instructions for Concrete and Masonry Arches been followed per the Bridge Manual, Part I, Chapter 7, Section 7.2, Subsection 7.2.7 and Subsection 7.2.8? For non-arch structures select NO (N).

Explanation:

Corroded Steel Beam Webs

Y **N**
 Have the special instructions for Corroded Steel Beam Webs been followed per the Bridge Manual, Part I, Chapter 7, Section 7.2, Subsection 7.2.9? For non-steel structures and structures without web losses select NO (N).

Explanation:

Deteriorated Prestressed Beams

Y **N**
 Have the special instructions for Deteriorated Prestressed Beams been followed per the Bridge Manual, Part I, Chapter 7, Section 7.2, Subsection 7.2.10? For non-prestress and those without deterioration select NO (N).

Explanation:

8. EVALUATION OF RATING AND RECOMMENDATIONS

Y **N**
 Is the Evaluation of Rating provided per the Bridge Manual, Part I, Chapter 7, Section 7.2, Subsection 7.2.11, Paragraph 7.2.11.1? Are any significant differences between the current and prior rating identified and formatted per the Bridge Manual, Part I, Chapter 7, Figure 7.5.2-9?

Explanation:

Y **N**
 Are the Recommendations developed per the Bridge Manual, Part I, Chapter 7, Section 7.2, Subsection 7.2.11, Paragraph 7.2.11.2?

Explanation:

Y **N**
 Are the Recommendations for Immediate Action developed per the Bridge Manual, Part I, Chapter 7, Section 7.2, Subsection 7.2.11, Paragraph 7.2.11.3? If immediate action is not required, select NO (N).

Explanation:

9. AVAILABLE PLANS AND INSPECTION REPORTS

Y **N**
 Are all plans, latest inspection reports, and their respective sources that were available for the rating stated and included with the report? If a more recent inspection has been performed, but it is not available, has it been noted?

Explanation:

Y **N**
 Are copies of all plans, converted to PDF, combined into a single file per Construction Contract, provided in folders by date, per the Bridge Manual, Part I, Chapter 7, Section 7.5, Paragraphs 7.5.3.1 and 7.5.3.2?

Explanation:

10. LOADINGS USED FOR BRIDGE RATING

Y **N**
 For a Load Factor or Allowable Stress rating, are the standard diagrams of the H20, Type 3, Type 3S2, HS20, SU4, SU5, SU6, SU7, EV2, and EV3 vehicles showing axle weights and spacing included per the Bridge Manual, Part I, Chapter 7, Figures 7.5.2-10B, 7.5.2-11, and 7.5.2-12? For a Load and Resistance Factor rating select NO (N).

Explanation:

Y **N**
 For a Load and Resistance Factor rating, are the standard diagrams of the H20, Type 3, Type 3S2, SU4, SU5, SU6, SU7, EV2, and EV3 vehicles, and HL-93 loading showing axle weights and spacing included per the Bridge Manual, Part I, Chapter 7, Figures 7.5.2-10A, 7.5.2-11, 7.5.2-12, and 7.5.2-13A? For a Load Factor or Allowable Stress rating select NO (N).

Explanation:

11. APPENDIX A: INSPECTION REPORTS

Y **N** Does the SI&A sheet appear first?
 (A NO (N) response indicates a FATAL OMISSION.)

Y **N** Is the latest available Routine or Routine & Special Member Inspection Report included? (A NO (N) response indicates a FATAL OMISSION.)

Explanation:

Y **N** Are all the photos in the inspection report in color?
 (A NO (N) response indicates a FATAL OMISSION.)

Explanation:

Y **N** Are Special Member, Fracture Critical, and/or Underwater Inspection Reports included if available?

Explanation:

12. APPENDIX B: PHOTOS

Y **N** Is an index of the photographs included?

Y **N** Do the photographs contain both elevation views, views of both approaches, top of deck, views from both sides of the feature crossed, views of each substructure, and framing views (if various, one of each type), including sufficient critical members and deficiencies?

Explanation:

Y **N** Have photographs been included depicting deficiencies, or areas of deficiency, that are considered in the Computations?
 (A NO (N) response indicates a FATAL OMISSION.)

Explanation:

Y **N** Are all of the photos in color and no smaller than 3" x 5"?

Explanation:

13. APPENDIX C: COMPUTATIONS

Y **N** Is an Index of the calculations included?

Y **N** Is the written agreement of the Independent Reviewer (Statement of Concurrence) included, signed, dated, and stamped by a Professional Engineer per the Bridge Manual, Part I, Chapter 7, Section 7.4, Subsection 7.4.3? (A NO (N) response indicates a FATAL OMISSION.)

Explanation:

13. APPENDIX C: COMPUTATIONS (continued)

Y **N**
 Do all calculation headers include a company logo, note who calculated by, who checked by, and date?

Explanation:

Y **N**
 Is a summary table of all the dead loads and live load distribution factors, including a breakdown of the dead loads (self, non-composite, composite, wearing surface, etc.) with sketches and references included?

Explanation:

Y **N**
 Are dead loads distributed per the Bridge Manual, Part I, Chapter 7, Section 7.2, Subsection 7.2.3?

Explanation:

Y **N**
 For a Load and Resistance Factor rating is a summary of the live load factors used for the vehicles included? For a Load Factor or Allowable Stress rating select NO (N).

Explanation:

Y **N**
 Are the live load distribution factors calculated per the Bridge Manual, Part I, Chapter 7, Section 7.2, Subsection 7.2.4 and AASHTO?

Explanation:

Y **N**
 Does the electronic submission contain an Adobe Acrobat (.PDF) file of the entire report and all analysis software input and output files (AASHTOWare, MIDAS, CSIBridge, etc.), the calculation files, and the plans per the Bridge Manual, Part I, Chapter 7, Section 7.3, Subsection 7.3.1? (A NO (N) response indicates a FATAL OMISSION.)

Explanation:

Y **N**
 Are all electronic files used for the development of the rating (i.e. Excel, MathCAD, AutoCAD, etc.) included in the electronic submission? (A NO (N) response indicates a FATAL OMISSION.)

Explanation:

Y **N**
 Are the calculations/steps easy to follow and do they include code section references, define variables, and clearly depict original equations noting the equation number, if applicable? (A NO (N) response indicates a FATAL OMISSION.)

Explanation:

14. APPENDIX D: COMPUTER INPUT AND OUTPUT

Y

N

Is the analysis software file named per the Bridge Manual, Part I, Chapter 7, Section 7.4, Subsection 7.4.2, Paragraph 7.4.2.3?
(A NO (N) response indicates a FATAL OMISSION.)

Explanation:

15. DISTRIBUTION

Y

N

Has the electronic submission been distributed per the Bridge Manual, Part I, Chapter 7, Section 7.3, Subsection 7.3.2?

Explanation:

Additional/Supplemental Information